

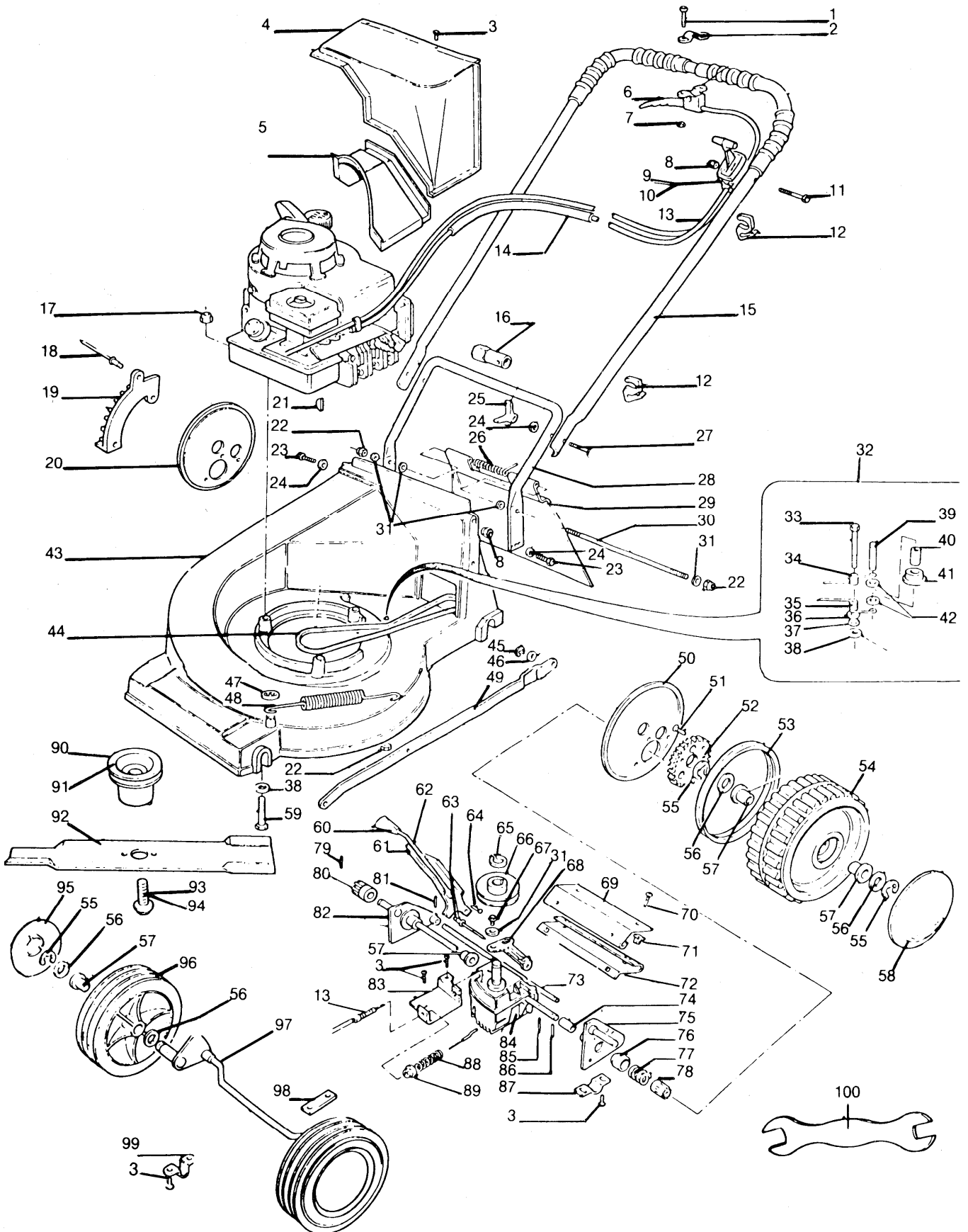

GXL 9641127
GXL-05 9641132



Flymo

GXL 9641127
GXL-05 9641132

KEY No.	PART No.	DESCRIPTION	QUANTITY	COMMENTS/ APPLICATION	KEY No.	PART No.	DESCRIPTION	QUANTITY	COMMENTS/ APPLICATION
3	5141725-02/7	SCREW TAPTITE	7		61	5126198-01/8	ADJUSTER LOWER	1	
4	5106075-00/4	DRIVE COVER UPPER	1		62	5136382-00/8	ADJUSTER UPPER	1	
5	5116416-00/8	DRIVE COVER LOWER	1		63	5147156-00/3	RIVET	1	
6	5136405-00/7	HANDLE CLUTCH	1		64	5141729-02/9	RIVET	1	
7				NO LONGER AVAILABLE	65	5147062-00/3	CIRCLIP	1	
8	5140164-00/4	NUT LOCKING	1		66	5136338-00/0	PULLEY GEARBOX	1	
9	5130480-00/6	CONTROL THROTTLE	1	GXL 3.5 HP	66A	5147070-00/6	KEY WOODRUFF	1	NOT ILLUSTRATED
10	5136417-00/2	CONTROL THROTTLE	1	GXL-05 5HP	67	5147063-00/1	SCREW	1	
11	5140045-06/2	SCREW 1/4 UNC	1		68	5136369-01/3	LEVER	1	
12	5140863-01/9	CABLE CLIP LARGE	2		69	5126255-01/6	COVER UPPER	1	
13	5136404-00/0	CABLE CLUTCH	1		70	5141599-00/0	SCREW	4	
14	5146364-00/4	SLEEVE	1		71	5147068-00/0	SCREW INSERT	4	
15	5147545-00/7	HANDLE UPPER	1		72	5126256-01/4	COVER LOWER	1	
16	5146392-02/1	SPANNER PLUG	1	NO LONGER AVAILABLE	73	5147065-00/6	ROD	1	
17	5140837-00/5	NUT NYLOC 5/16 UNC.	3		74	5147061-00/5	BEARING	2	
18	5146538-00/3	RIVET	3		75	5136346-00/3	FLANGE PLATE L/H	1	
19	5120414-01/5	BRACKET WHEEL ADJUST	1		76	5147060-00/7	CAP	2	
20	5136333-02/7	COVER L/H	1		77	5147059-00/9	SPRING	2	
21	5140053-00/9	KEY	1		78	5147069-00/8	GEAR DRIVE L/H	1	
22	5141131-00/2	NUT	3		79	5147537-00/4	PIN DRIVE	2	
23	5141407-00/6	BOLT	2		80	5147058-00/1	GEAR DRIVE R/H	1	
24	5140281-03/0	WASHER	4		81	5147152-00/2	PIN	1	
25	5140690-00/8	KNOB WING	2		82	5136345-00/5	FLANGE PLATE R/H	1	
26	5136087-00/3	SPRING SAFETY FLAP	1		83	5126264-00/0	BRACKET CABLE	1	
27	5140607-00/2	BOLT HANDLE 1/4 UNC X 45 LG	2		84	5116334-00/3	GEARBOX	1	
28	5116313-03/1	HANDLE LOWER	1		84A	5147455-00/9	DUST SHIELD	1	NOT ILLUSTRATED
29	5116314-02/1	FLAP SAFETY	1		84B	5147456-00/7	SCREW	1	FITTED TO
30	5136074-01/9	TIE BAR	1		84C	5147463-00/3	CIRCLIP	2	GEAR BOX
31	5147064-00/9	WASHER	5		85	5147057-00/3	PIN	2	
32	5126367-00/1	BELT TENSIONER ASSY	1		86	5147537-00/4	PIN DRIVE	2	
43	5116320-00/2	CHASSIS	1		87	5146862-01/5	BRACKET	2	
43A	5126263-00/2	GEAR BOX COVER	2		88	5147093-00/8	SPRING	1	NO LONGER FITTED
43B	5141725-00/1	SCREW TAPTITE	3		89	5147681-00/0	NUT STEEL	2	
44	5147680-00/2	BELT	1		90	5136337-00/2	PULLEY ENGINE	1	GXL 3.5 HP
45	5141727-00/7	RETAINING RING 3/8"	2		91	5136362-00/0	PULLEY ENGINE	1	GXL-05 5 HP
46	5147064-00/9	WASHER	2		92	5116066-00/1	BLADE 45 CM	1	
47	5141728-02/1	LOCKNUT PUSH ON 3/8"	1		93	5146677-06/6	BOLT BLADE 37MM LONG	1	GXL 3.5 HP
48	5141693-00/1	SPRING	1		94	5146677-01/7	BOLT BLADE 61.5MM LONG	1	GXL-05 5 HP
49	5120391-01/5	ADJUSTER LINK HOC	1		95	5126176-00/6	DISC WHEEL	2	
50	5136340-02/2	COVER R/H	1		96	5146494-00/9	WHEEL	2	
51	5146045-02/5	SCREW NO 10X32LG POZI PAN	6		97	5126051-01/9	AXLE FRONT	1	
52	5136352-00/1	GEAR	2		98	5146303-02/8	BRACKET RETAINING AXLE	2	
53	5136339-00/8	GASKET	2		99	5146304-02/6	BRACKET	2	
54	5126193-00/1	WHEEL REAR	2		100	5136442-00/0	SPANNER	1	
55	5141755-00/8	RING RETAINER	4						
56	5140281-01/4	WASHER	6						
57	5136390-00/1	BEARING	5						
58	5126176-00/6	DISC WHEEL	2						
59	5140045-10/4	SCREW	3						
60	5130448-00/3	KNOB HANDLE GRIP	1						

PLEASE NOTE: KEYS 1, 2, 33-42 ARE NO LONGER AVAILABLE, USE LISTED COMPLETE ASSY.

PRODUCT VARIANT

9641127-01 GB	9641127-11 I.P.E.	9641132-06 DK.SF.N.	9641132-11 I.P.E.
9641127-06 DK.SF.N.	9641127-17 O/S.	9641132-09 F.D.NL.CH.B.A.	9641132-17 O/S.
9641127-09 F.D.NL.CH.B.A.	9641132-01 GB.		

Where no application details are shown the part applies to all countries.