

MODEL	GT2	PRODUCT APPLICATION	
		9631045-59 A,B,D,E,F,GB,EI,NL,DK,NL,S,SF	
PRODUCT NO.	9631045		

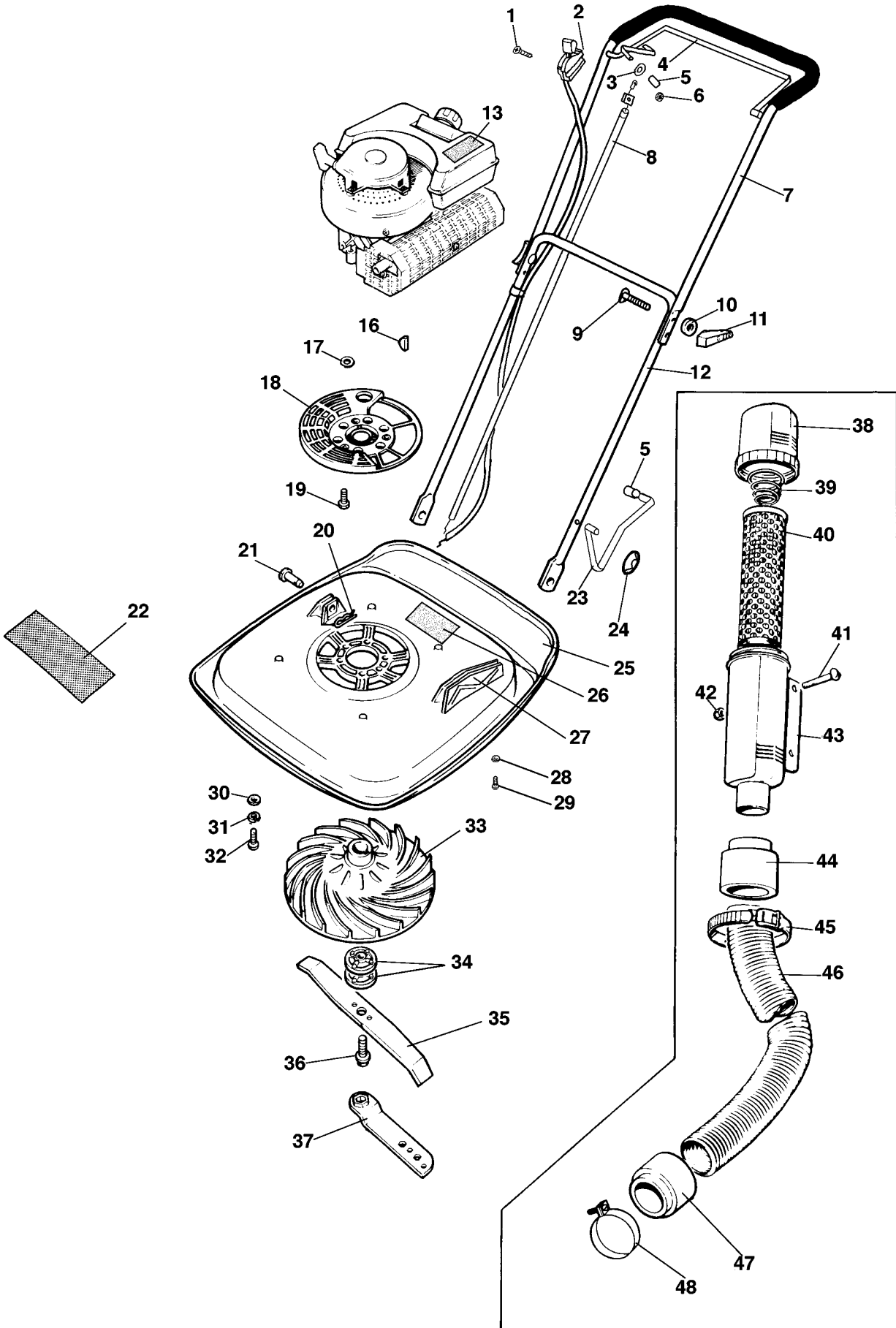

MODEL	GT2	PRODUCT APPLICATION 9631045-59 A,B,D,E,F,GB,EI,NL,DK,NL,S,SF	
PRODUCT NO.	9631045		



KEY	PARTNUMBER	QTY	
01	5148636-00/3	2	BOLT
02	5127509-00/7	1	CHOKE CONTROL
03	5149275-00/9	1	SPACER
04	5118010-00/7	1	LEVER
05	5146476-00/6	2	KNOB
06	5148637-00/1	2	NUT
07	5117812-04/9	1	HANDLE, UPPER
08	5138367-00/7	1	CABLE-BRAKE
09	5148672-00/8	2	BOLT,HANDLE
10	5140266-00/7	2	WASHER
11	5137679-00/6	2	WING KNOB
12	5126696-07/8	1	HANDLE, LOWER
13	5149173-00/6	1	LABEL
16	5140053-00/9	1	KEY
17	5141737-03/0	1	PROTECTION SLINGER
18	5106708-00/0	1	ADAPTOR PLATE
19	5149430-00/0	3	BOLT
20	5140423-00/4	2	PIN RETAINING
21	5140092-03/1	2	PIVOT PIN
22	5117140-03/7	1	LABEL, FLYMO
23	5127537-00/8	1	HOOK,SLOTTED GUIDE
24	5146682-00/9	1	WASHER,STARLOCK
25	5106206-07/0	1	HOOD
26	5138258-01/6	1	LABEL, WARNING
27	5126210-00/3	1	SLOTTED GUIDE
28	5140943-00/1	3	WASHER
29	5146824-00/7	3	SCREW
30	5146309-00/9	6	WASHER
31	5147524-00/2	6	WASHER
32	5141585-01/7	6	SCREW
33	5116968-06/5	1	IMPELLER
34	5138340-00/4	2	BLADE SPACER
35	5118008-03/5	1	BLADE
36	5146677-04/1	1	BLADE BOLT
37	5130109-00/1	1	SPANNER
38	5146712-00/4	1	CAP
39	5146713-00/2	1	SPRING
40	5146714-00/0	1	ELEMENT
41	5149311-00/2	2	SCREW
42	5146314-00/9	2	NUT
43	5146715-00/7	1	FILTER BODY
44	5141703-00/8	1	FITTING
45	5140357-00/4	1	HOSE STRAP
46	5140350-01/7	1	HOSE
47	5141703-00/8	1	FITTING
48	5146419-00/6	1	HOSE CLIP