

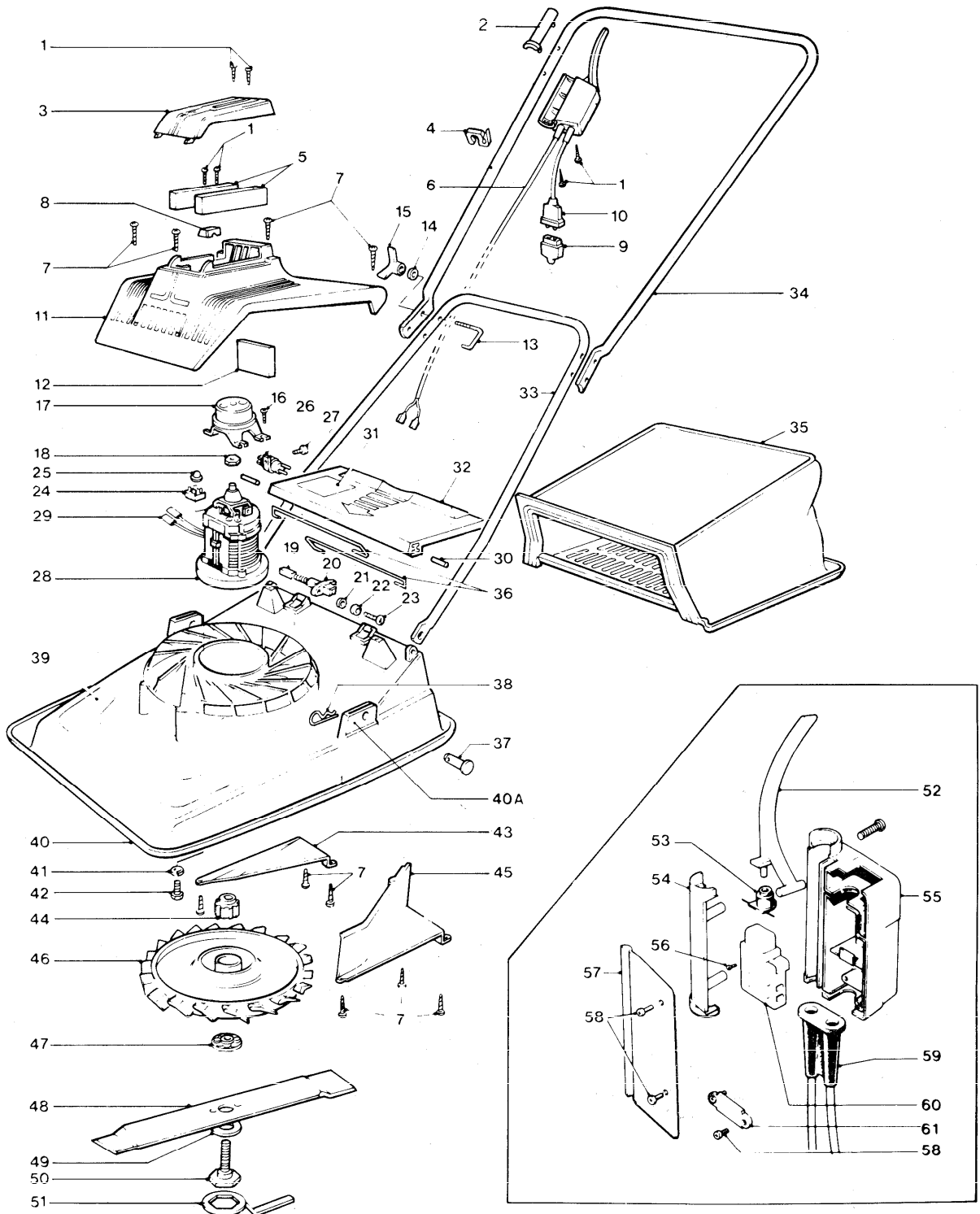

XE-47-S 9635461 9635462





XE-47-S 9635461 9635462

KEY No.	PART No.	DESCRIPTION	QUANTITY	COMMENTS APPLICATION	KEY No.	PART No.	DESCRIPTION	QUANTITY	COMMENTS APPLICATION
1	5146672-00/0	SCREW GKN POLYMATE No 6	6		30	5147723-00/0	PIN PIVOT	2	
2	5126378-01/6	SWITCHBOX RETAINER 18mm	1		31	5146467-00/5	LABEL WARNING	1	GB.O/S.E.P.IE.
3	5116620-00/5	MOTOR COVER	1			5136507-00/0	LABEL WARNING	1	A.D.CH.
4	5140863-01/9	CABLE CLIP LARGE	2			5146466-00/7	LABEL WARNING	1	DK.N.F.B.
5	5147720-00/6	FILTER	2			5136361-00/2	LABEL WARNING	1	SF.
6	5147001-06/8	LEAD INTERNAL	1			5146486-00/5	LABEL WARNING	1	I.
7	5147665-00/4	SCREW	4		32	5116619-00/7	SAFETY FLAP	1	
8	5136587-00/2	BELLMOUTH CLAMP	1		33	5106110-00/9	HANDLE LOWER	1	
9	5136662-00/3	SOCKET FEMALE 10 AMP	1	GB.	34	5106172-01/7	HANDLE UPPER	1	
10	5136621-00/9	LEAD TERMINAL C/W PLUG	1	GB.		5136573-07/7	HANDLE CORD GUIDE ASSY	1	D.
	5147000-02/9	LEAD TERMINAL	1		35	5106117-00/4	BAG ASSY	1	
	5147000-04/5	LEAD TERMINAL	1	CH.	36	5147721-00/4	SPRING	2	
11	5106113-03/7	COWLING	1		37	5140092-01/5	PIN LOCKING	2	ALT USE 5140092-00/7
12	5147719-00/8	FILTER	1		38	5140423-00/4	PIN RETAINING	2	
13	5147542-00/4	J BOLT	2		39	5126380-00/4	LABEL XE47S	1	
14	5140266-00/7	WASHER	2		40	5106114-01/9	HOOD	1	
15	5140690-00/8	KNOB WING	2		40A	5147594-00/5	PIN	2	
16	5147114-00/2	SCREW TAPTITE UNC 3/8" LNG	4		41	5146309-00/9	WASHER	4	
17	5126284-03/2	BRAKE 220/240 V	1	USE 5126284-83/4	42	5141585-01/7	SCREW	4	
18	5136429-00/7	ADAPTOR BRAKE HUB	1	NLA AS A PARTS ITEM	43	5116626-00/2	DEFLECTOR PLATE	1	
19	322824-00/4	CARBON BRUSH COMPLETE	2		44	5126133-00/7	PINION IMPELLOR	1	
20	322819-00/4	BRUSH HOUSING COMPLETE	2		45	5106119-00/0	PLATE	1	
21	29100-00/5	WASHER	4		46	5116615-00/5	IMPELLOR	1	
22	322827-00/7	SPRING WASHER PLATED	4		47	5136668-01/8	BLADE SPACER	4	
23	321689-00/2	SCREW M4 x 16	4		48	5116647-00/8	BLADE 47 CM	1	
24	322814-00/5	RECTIFIER	1		49	5140516-00/5	ANTI FRICTION WASHER (PTFE)	1	
25	323440-00/8	SPEED FASTNER CAP	1		50	5136242-01/2	BLADE BOLT	1	
26	323183-00/4	SUPPRESSOR	1		51	5130127-00/3	SPANNER	1	
27	2902868-00/5	SCREW SUPADRIIVE PAN M4x19	1		52	5136182-01/0	LEVER SWITCH	1	
28	5147434-01/2	MOTOR 240 VOLT C/W HUB	1		53	5130406-01/9	SEAL CONE	1	
	5147434-02/0	MOTOR 220 VOLT C/W HUB	1		54	5126378-01/6	SWITCHBOX RETAINER 18mm	1	
29	5147591-00/1	RECTIFIER LEAD	2		55	5116641-01/9	SWITCHBOX BODY	1	
					56	5141605-00/5	SCREW	4	
					57	5116495-00/2	SWITCHBOX COVER	1	
					58	5146672-00/0	SCREW GKN POLYMATE No 6	4	
					59	5141584-01/0	SLEEVE PROTECTION	1	
					60	5141586-14/8	SWITCH ON/OFF THERMAL CUT OUT	1	KOPP 2401-18
					61	5146616-00/7	CLAMP CABLE	1	

PRODUCT VARIANT

9635461-01 GB.	9635462-07 SF.	9635462-09 D.	9635462-16 O/S.E.P.IE.
9635462-03 A.	9635462-08 F.B.NL.	9635462-11 I.	9635462-22 CH.
9635462-06 DK.N.			

When no application details are shown the part applies to all countries.