

Flymo

MODEL

XE400

PRODUCT NO.

9634022, 9634023, 9634024

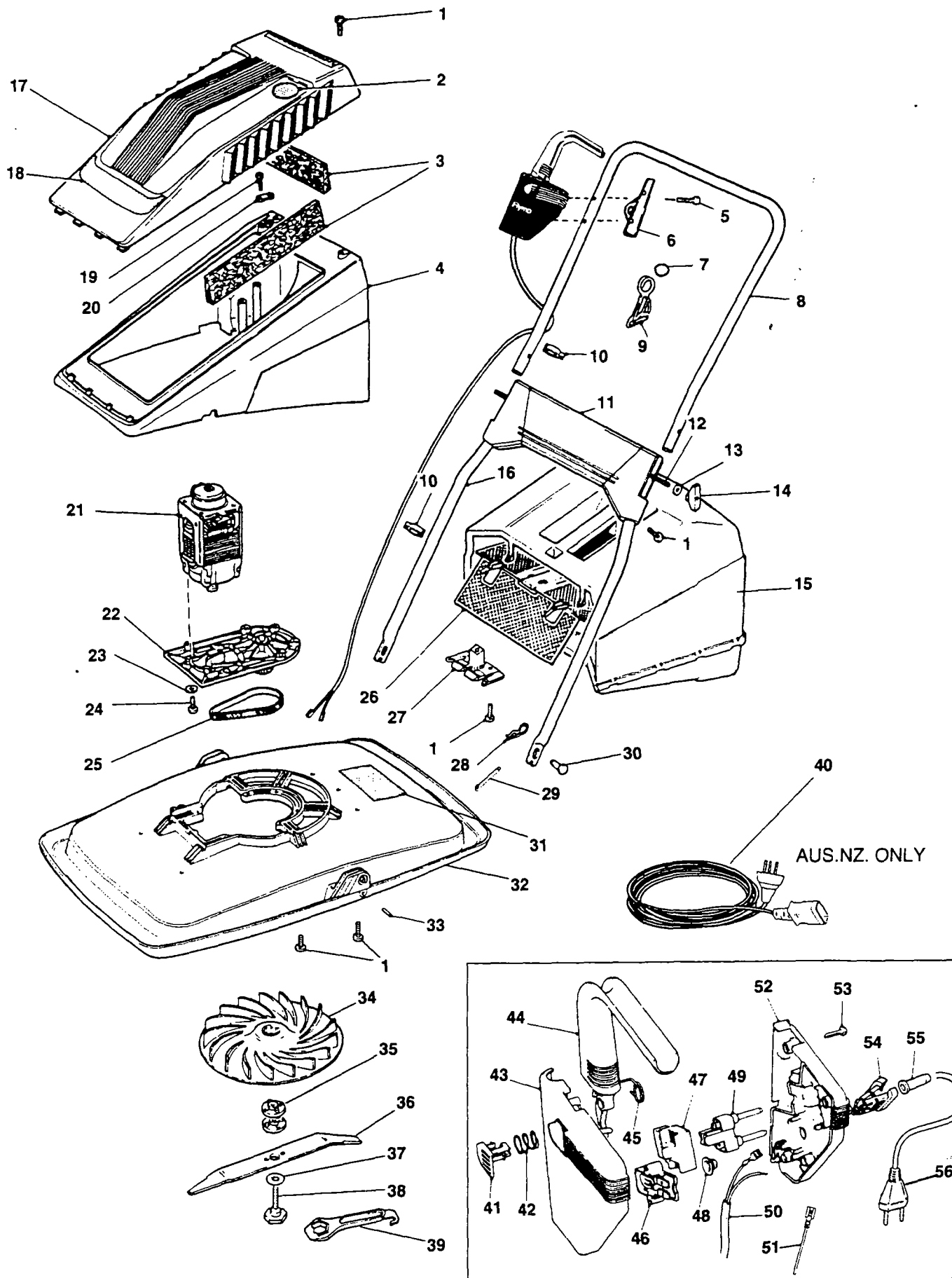

Flymo

| | |
|-------------|---------------------------|
| MODEL | XE400 |
| PRODUCT NO. | 9634022, 9634023, 9634024 |

| KEY | PART NUMBER | DESCRIPTION | QTY | KEY | PART NUMBER | DESCRIPTION | QTY |
|-----|--------------|----------------------------|---------------------|-----|--------------|-------------------|---|
| 01 | 5148649-01/4 | SCREW | 21 | 50 | 5148814-18/8 | LEAD | 1 A.B.D.NL.F.I.E.P. |
| 02 | 5137855-01/0 | LABEL.AUTOSTOP | 1 | | | | N.DK.S.SF. |
| 03 | 5138096-00/2 | FILTER | 3 | | 5148814-20/4 | LEAD | 1 AUS.NZ.CH. |
| 04 | 5106375-68/5 | COWL LOWER | 1 | 51 | 5148773-00/4 | INTERNAL LEAD | 1 |
| 05 | 5146672-00/0 | SCREW | 2 | 52 | 5106540-01/5 | SWITCHBOX LOWER | 1 A.B.D.NL.F.I.E.P. |
| 06 | 5117657-01/4 | RETAINER, SWITCHBOX | 1 | | | | N.DK.S.SF. |
| 07 | 5148886-00/4 | SPLIT RING | 1 CH.N.DK.S.SF. | | 5106538-01/9 | SWITCHBOX LOWER | 1 AUS.NZ.CH. |
| 08 | 5117402-01/5 | HANDLE.UPPER | 1 | 53 | 5146672-00/0 | SCREW | 4 |
| 09 | 5138024-00/4 | CORD GUIDE | 1 A.B.D.NL.F.I.E.P. | 54 | 5117528-00/9 | CABLE RETAINER | 1 AUS.NZ.CH. |
| | 5126240-01/8 | CORD GUIDE | 1 CH.N.DK.S.SF. | 55 | 5148741-00/1 | PROTECTION SLEEVE | 1 AUS.NZ.CH. |
| 10 | 5137750-00/5 | CLIP CABLE | 2 | 56 | 5148280-04/2 | CONNECTING LEAD | 1 AUS.NZ. |
| 11 | 5106435-00/0 | CONSOLE | 1 | | 5147000-02/7 | CONNECTING LEAD | 1 CH. |
| 12 | 5148859-00/1 | BOLT,SQUARE HEAD | 2 | | | | |
| 13 | 5140266-00/7 | WASHER | 2 | | | | |
| 14 | 5137679-00/6 | KNOB WING | 2 | | | | |
| 15 | 5137966-01/5 | GRASSBOX | 1 | | | | |
| 16 | 5117863-01/8 | HANDLE.LOWER | 1 | | | | |
| 17 | 5117343-01/1 | COWL-UPPER | 1 | | | | |
| 18 | 5126732-01/4 | LABEL.FLYMO | 1 | | | | |
| 19 | 5146941-00/9 | SCREW | 2 | | | | |
| 20 | 5140705-00/4 | CABLE CLAMP | 1 | | | | |
| 21 | 5150010-02/2 | MOTOR 220V | 1 A.B.D.NL.F.I.E.P. | | | | |
| | | | | | | | N.DK.S.SF.CH. — Use on Product No: 9634023 ONLY |
| | 5150010-01/4 | MOTOR 240V | 1 AUS.NZ. | | | | ———— Use on Product No: 9634022 ONLY |
| | 5150010-00/6 | MOTOR 230V | 1 A.B.D.NL.F.I.E.P. | | | | N.DK.S.SF.CH. |
| 22 | 5137968-00/3 | BASEPLATE/PULLEY ASSY | 1 | | | | |
| 23 | 5140943-00/1 | WASHER | 4 | | | | |
| 24 | 5148696-03/1 | MOTOR SCREW | 4 | | | | |
| 25 | 5137872-00/7 | DRIVE BELT | 1 | | | | |
| 26 | 5106571-00/2 | SCREEN.GRASSBOX | 1 | | | | |
| 27 | 5126989-00/2 | GRASSBOX CLIP | 1 | | | | |
| 28 | 5140423-00/4 | PIN RETAINING | 2 | | | | |
| 29 | 5141424-01/9 | SPLIT PIN | 1 AUS.NZ. | | | | |
| 30 | 5140092-03/1 | PIVOT PIN | 2 | | | | |
| 31 | 5138319-00/8 | LABEL,WARNING | 1 | | | | |
| 32 | 5137890-00/9 | HOOD 40CM | 1 | | | | |
| 33 | 5147594-00/5 | PIN | 2 | | | | |
| 34 | 5117227-01/6 | IMPELLER | 1 | | | | |
| 35 | 5138110-01/9 | BLADE SPACER PEGGED | 3 | | | | |
| 36 | 5126995-00/9 | BLADE 40CM | 1 | | | | |
| 37 | 5148259-00/4 | WASHER ANTI FRICTION PTFE | 1 | | | | |
| 38 | 5137608-00/5 | BLADE BOLT C/W PTFE WASHER | 1 | | | | |
| 39 | 5126682-00/3 | SPANNER/SCRAPER | 1 | | | | |
| 40 | 5126968-00/6 | EXTENSION CABLE | 1 AUS.NZ. | | | | |
| 41 | 5127008-00/0 | LOCK OFF | 1 | | | | |
| 42 | 5148658-00/7 | SPRING-LOCK OFF | 1 | | | | |
| 43 | 5106539-01/7 | SWITCHBOX UPPER | 1 | | | | |
| 44 | 5106481-01/2 | LEVER | 1 | | | | |
| 45 | 5148657-00/9 | SPRING-TORSION | 1 | | | | |
| 46 | 5127255-00/7 | THERMAL CUT-OUT | 1 | | | | |
| 47 | 5137786-00/9 | SWITCH | 1 | | | | |
| 48 | 5149024-00/1 | CUT-OUT COVER | 1 | | | | |
| 49 | 5148784-00/1 | PIN RETAINER ASSY | 1 A.B.D.NL.F.I.E.P. | | | | |
| | | | | | | | N.DK.S. |

PRODUCT APPLICATION

| | | | | | |
|------------|-------------|------------|-------------------|------------|-------------------|
| 9634022-99 | AUS.NZ. | 9634023-81 | N.DK.S. | 9634024-27 | N.DK.S.SF. |
| 9634023-20 | A.B.D.NL.F. | 9634023-85 | A.B.D.NL.F.I.E.P. | 9634024-85 | A.B.D.NL.F.I.E.P. |
| 9634023-22 | CH. | 9634024-01 | GB.EI. | | |
| 9634023-27 | N.DK.S.SF. | 9634024-22 | CH. | | |

WHERE NO APPLICATION DETAILS ARE SHOWN, PART APPLIES TO ALL COUNTRIES

A Austria; AUS Australia; B Belgium; CND Canada; CH Switzerland; D Germany; DK Denmark; E Spain; EI Eire; F France; GB Great Britain; I Italy; N Norway; NL Netherlands; NZ New Zealand; O/S Overseas; P Portugal; S Sweden; SF Finland; USA America; ZA South Africa