

Flymo

C11
XE30-11A
9633029

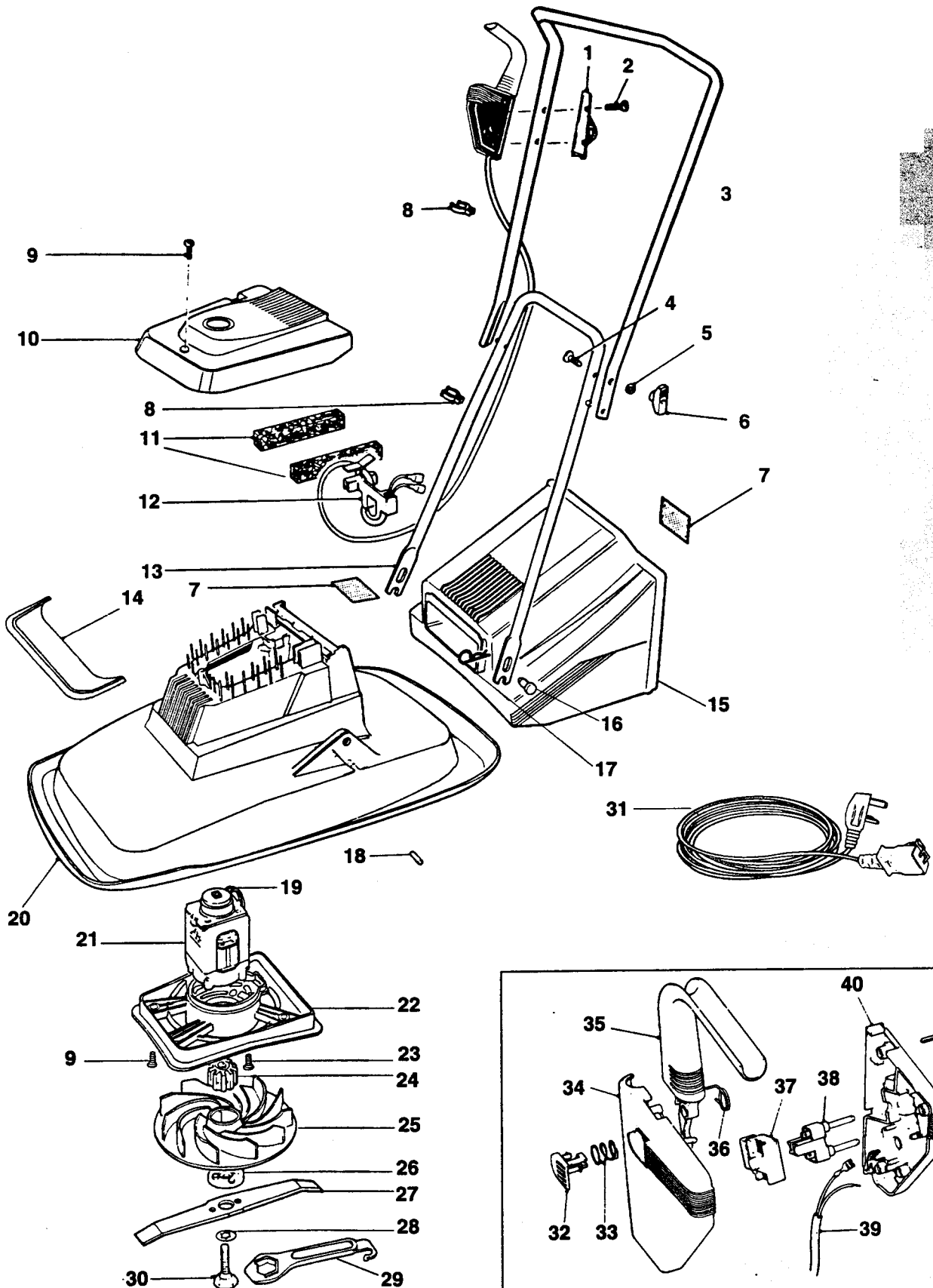

Flymo

C12

XE30-11A
9633029

KEY	PART NUMBER	DESCRIPTION	QTY
01	5117659-01/0	RETAINER	1
02	5146672-00/0	SCREW	2
03	5126816-21/3	HANDLE-LABEL ASSEMBLY	1
04	5148672-00/8	BOLT,HANDLE	2
05	5140266-00/7	WASHER	2
06	5137679-00/6	WING KNOB	2
07	5146467-00/5	LABEL,WARNING	2
08	5137750-00/5	CLIP CABLE	2
09	5146736-00/3	SCREW	5
10	5126821-19/7	COVER ASSY	1
11	5137638-00/2	FILTER	2
12	5126741-00/7	CLAMP PLASTIC	1
13	5117690-01/5	HANDLE LOWER	1
14	5126885-01/0	LABEL FLYMO	1
15	5117079-06/0	GRASSBOX ASSY	1
16	5140092-03/1	PIVOT PIN	2
17	5140423-00/4	PIN RETAINING	2
18	5147594-00/5	PIN	2
19	5146469-01/9	WARNING DISC ASSY	1
20	5126819-01/9	HOOD 30CM	1
21	5150006-01/2	MOTOR - 240V	1
22	5106491-00/3	MOTOR MOUNTING PLATE	1
23	5148122-01/2	SCREW PLASTITE	4
24	5126764-00/9	INSERT,IMPELLER	1
25	5116967-10/9	IMPELLER	1
26	5138110-01/9	BLADE SPACER	3
27	5126439-00/8	BLADE 30CM	1
28	5148259-00/4	WASHER ANTI FRICTION PTFE	1
29	5126682-00/3	SPANNER/SCRAPER	1
30	5137608-00/5	BLADE BOLT C/W PTFE WASHER	1
31	5127250-01/6	MAINS LEAD	1
32	5127008-00/0	LOCK OFF	1
33	5148658-00/7	SPRING,LOCK OFF	1
34	5106539-01/7	SWITCHBOX UPPER	1
35	5106481-01/2	LEVER	1
36	5148657-00/9	SPRING,TORSION	1
37	5141586-12/2	SWITCH	1
38	5137686-00/1	PIN RETAINER	1
39	5148814-11/3	LEAD	1
40	5106538-00/1	SWITCHBOX LOWER	1
41	5146672-00/0	SCREW	4

PRODUCT APPLICATION
9633029-01 GB

WHERE NO APPLICATION DETAILS ARE SHOWN, PART APPLIES TO ALL COUNTRIES
A Austria; AUS Australia; B Belgium; CND Canada; CH Switzerland; D Germany; DK Denmark; E Spain; EI Eire; F France;
GB Great Britain; I Italy; N Norway; NL Netherlands; NZ New Zealand; O/S Overseas; P Portugal; S Sweden; SF Finland;
USA America; ZA South Africa