

Flymo

XE 28 9635224

XE 28-2 9635231 9635232

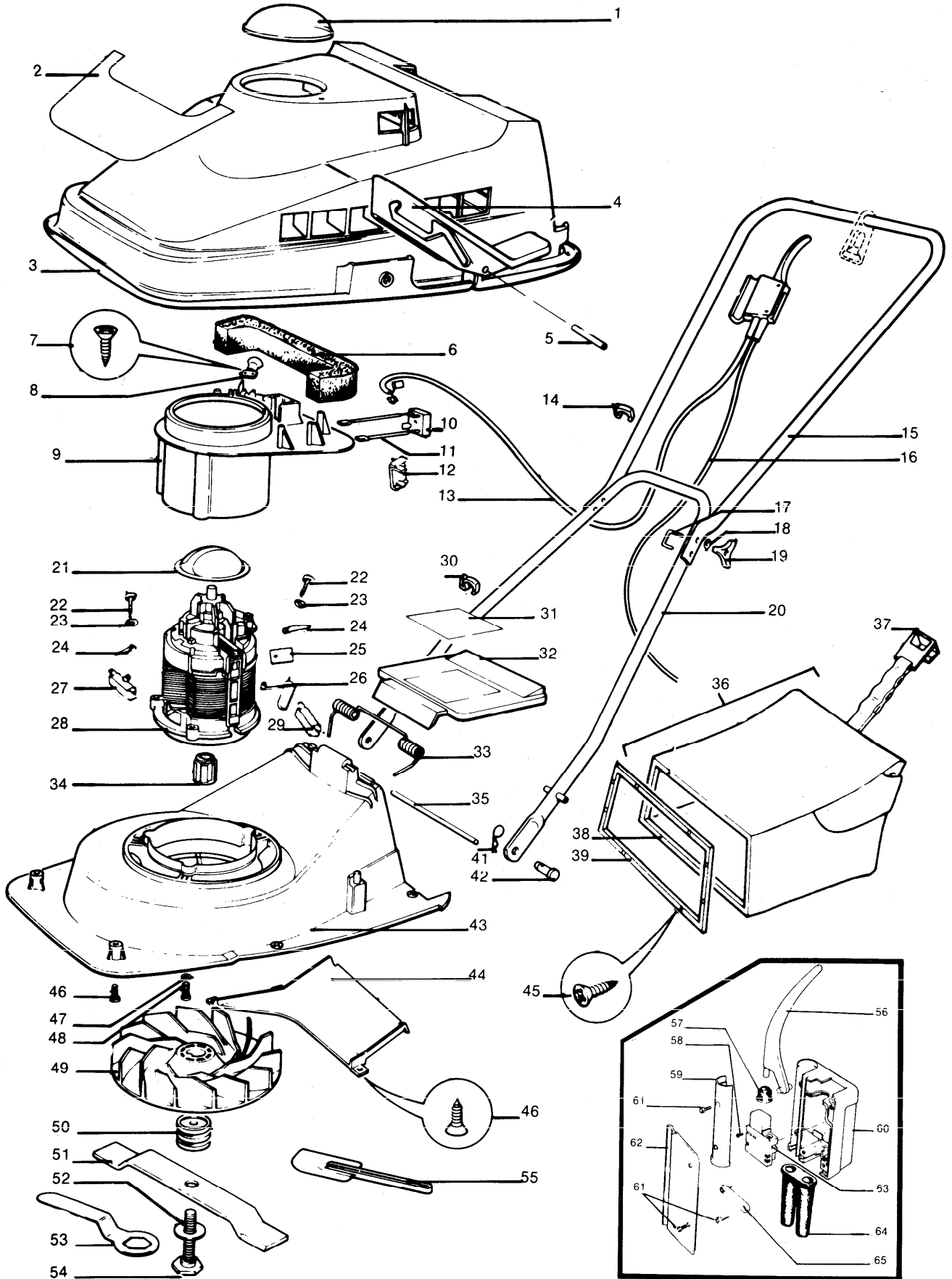



XE 28 9635224
XE 28-2 9635231 9635232

KEY No.	PART No.	DESCRIPTION	QUANTITY	COMMENTS/ APPLICATION	KEY No.	PART No.	DESCRIPTION	QUANTITY	COMMENTS/ APPLICATION
1	5126120-02/0	LENS	1		32	5116179-01/0	FLAP REAR SAFETY	1	ALT USE 5116922-00/5
2	5116392-00/1	LABEL FLYMO XE	1	ALT USE 5136725-00/8	33	5136274-00/7	SPRING LOCK	1	
3	5106054-02/5	COWLING	1		34	5136297-00/8	INSERT	1	
4	5116388-01/7	LEVER UP STOP	1	ALT USE 5116388-04/1	35	5146622-04/7	RETAINING ROD	1	
5	5147029-01/0	ROLL PIN	1		36	5126137-00/8	BAG ASSY COMPLETE	1	
6	5136440-00/4	FILTER	1		37	5136225-00/9	CLIP	1	
7	5147025-00/0	SCREW	2		38	5116180-00/0	FRAME BAG INNER	1	
8	5136480-00/0	CABLE CLAMP	1		39	5106029-00/1	FRAME BAG OUTER	1	
9	5116383-00/0	FILTER SUPPORT	1		40	5116207-00/1	BAG GRASS ONLY	1	
10	322814-00/5	RECTIFIER	1		41	5140423-00/4	PIN RETAINING	2	
11	5147591-00/1	RECTIFIER LEAD	2		42	5140092-01/5	PIN LOCKING	2	ALT USE 5140092-00/7
12	5136441-00/2	BRACKET	1	FITTED TO EARLY PRODUCTS	43	5106053-01/9	HOOD	1	
13	5147001-01/9	LEAD INTERNAL	1	GB.A.N.DK.F.B.NL.I.	44	5116390-00/5	DEFLECTOR PLATE	1	
14	5140482-00/0	CABLE CLIP SMALL	1		45	5141599-00/0	SCREW	8	
15	5126371-00/3	HANDLE UPPPER 16mm	1	ALT USE 5126522-00/1	46	5146824-00/7	SCREW	7	ALT USE 5147665-00/4
	5126522-00/1	HANDLE UPPER 18mm**	1		47	5146309-00/9	WASHER	3	
	5136573-01/0	HANDLE UPPER	1	D.	48	5141585-01/7	SCREW	3	
16	5147001-07/6	LEAD TERMINAL 15.24M*	1	GB.O/S.E.P.	49	5116375-01/4	IMPELLER	1	
	5147001-03/5	LEAD TERMINAL .5M**	1	GB.O/S.E.P.EI.	50	5136240-01/6	BLADE SPACER	3	
	5136621-00/9	LEAD TERMINAL C/W PLUG	1	GB.	51	5126232-00/7	BLADE 28 cm	1	NLA USE 5126232-04/9
17	5147542-00/4	J BOLT	2		52	5140516-00/5	ANTI FRICTION WASHER (PTFE)	1	
18	5140266-00/7	WASHER	2		53	5130127-00/3	SPANNER	1	
19	5140690-00/8	KNOB WING	2		54	5136242-01/2	BLADE BOLT	1	
20	5126374-00/7	HANDLE LOWER	1		55	5136330-00/7	SPATULA CLEANING	1	
21	5136241-00/6	DISC WARNING ASSY	1		56	5136182-01/0	LEVER SWITCH	1	
22	7241293-61/7	SCREW THREAD FORMING	2		57	5130406-01/9	SEAL CONE	1	
23	7352136-51/4	LOCKWASHER	2		58	5141605-00/5	SCREW	4	
24	113721-00/5	CLIP	2		59	5126167-00/5	SWITCHBOX RETAINER 16mm*	1	
25	4000830-00/2	INSULATING TAB	1	NO LONGER FITTED		5126290-00/5	SWITCHBOX RETAINER 16mm**	1	
	7629125-07/6	TAB STRIP	1	NLA AS A REPLACEMENT PART		5126378-01/6	SWITCHBOX RETAINER 18mm	1	
27	113030-00/9	SUPPRESSOR 0.1 MF	1		60	5116494-03/9	SWITCHBOX BODY 16mm*	1	
28	5126433-01/9	MOTOR 240 VOLT *	1	LESS RECTIFIER		5116641-03/5	SWITCHBOX BODY 18mm**	1	LOCK OFF
	5126354-01/0	MOTOR 240 VOLT	1		61	5146672-00/0	SCREW GKN POLYMATE No 6	6	
	5126354-02/0	MOTOR 220 VOLT	1		62	5116210-00/5	SWITCHBOX COVER*	1	
	5126433-02/7	MOTOR 220 VOLT *	1	LESS RECTIFIER		5116495-00/2	SWITCHBOX COVER**	1	
29	113030-01/9	SUPPRESSOR 0.15 MF	1		63	5141586-15/5	SWITCH*	1	KOPP 2401-13
30	5140863-01/9	CABLE CLIP LARGE	1			5136674-01/6	SWITCH ON / OFF LOCK OFF	1	KOPP 2412.04 OR 2412.13
31	5146467-00/5	LABEL WARNING	2	GB.O/S.E.P.EI.ZA.	64	5141584-02/8	SLEEVE	1	
	5136507-00/0	LABEL WARNING	2	D.CH.A.	65	5146616-00/7	CLAMP CABLE	1	
	5136364-00/6	LABEL WARNING	2	N.					
	5146466-00/7	LABEL WARNING	2	N.DK.					
	5136361-00/2	LABEL WARNING	2	SF.					
	5146464-00/2	LABEL WARNING	2	F.B.NL.CH.					
	5146486-00/5	LABEL WARNING	2	I.					
	5146504-00/5	LABEL WARNING	2	S.					
	5136507-00/0	LABEL WARNING	2	D.CH.A.					

* Compatible parts fitted to early manufactured models 9635224.

** Compatible parts fitted to manufactured model 9635231.

PRODUCT VARIANT

9635224-01 GB.	9635224-09 D.	9635224-51 GB.	9635232-09 D.
9635224-03 A.	9635224-11 I.	9635231-25 GB.	9635232-11 I.
9635224-06 N.DK.	9635224-16 O/S.	9635231-51 GB.	9635232-17 O/S.
9635224-07 SF.	9635224-22 CH.	9635232-06 N.DK.	9635232-22 CH.
9635224-08 F.B.	9635224-25 GB.	9635232-08 F.B.NL.	