

MODEL	Venturer Turbo 300	PRODUCT APPLICATION
PRODUCT NO.	9643020	9643020-01 GB,EIRE. 9643020-99 AUS,NZ. 9643020-96 ZA

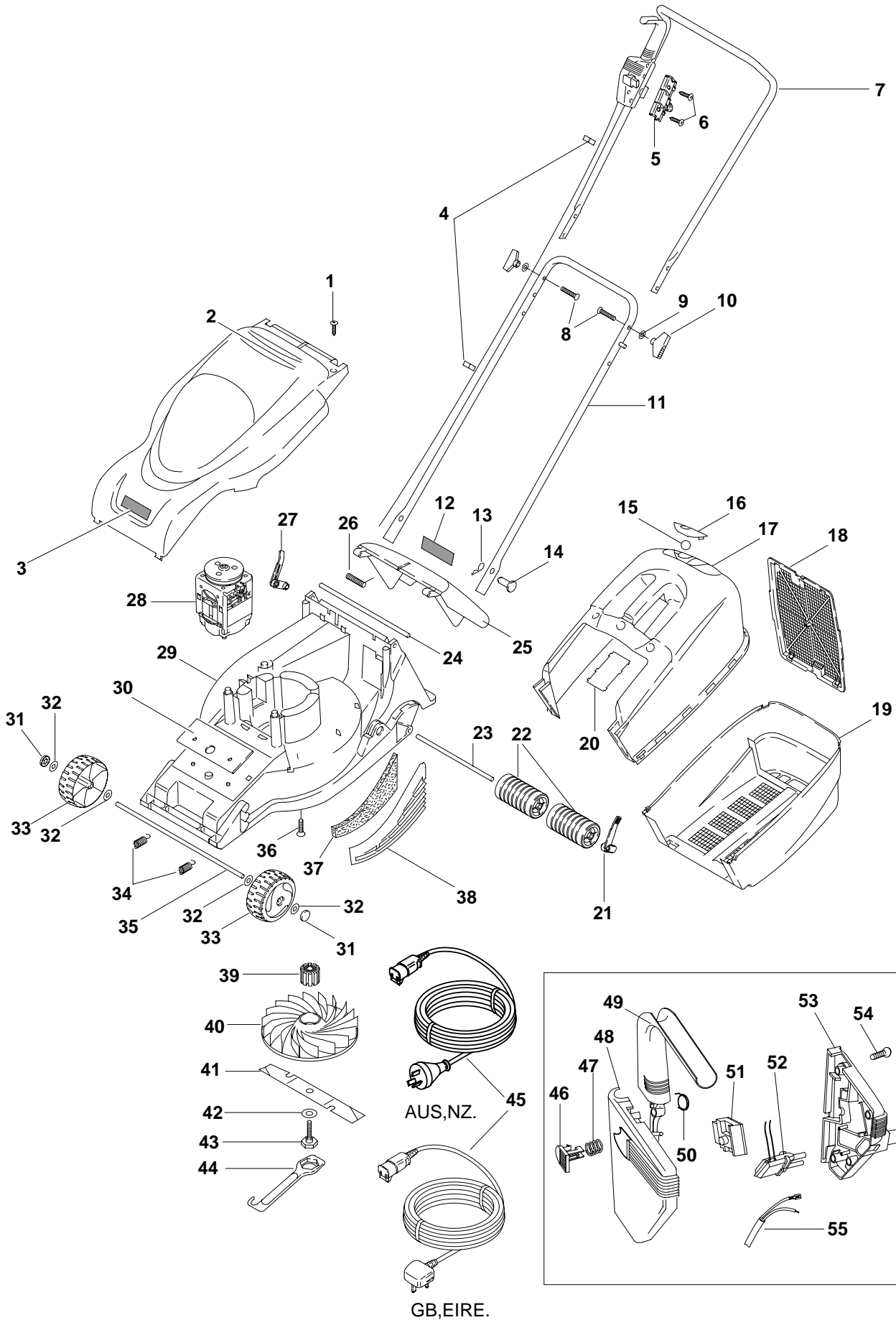



<b>MODEL</b>	<b>Venturer Turbo 300</b>	<b>PRODUCT APPLICATION</b>
<b>PRODUCT NO.</b>	<b>9643020</b>	9643020-01 GB,EIRE. 9643020-99 AUS,NZ. 9643020-96 ZA

1	KEY	PART NUMBER	DESCRIPTION	QTY
	01	5149088-00/6	SCREW	2
	02	5106758-00/5	COWL ASSEMBLY	1
	03	5149284-00/1	LABEL-FLYMO	1
	04	5137750-00/5	CLIP CABLE	2
	05	5118110-01/3	RETAINER	1
	06	5146672-00/0	SCREW	2
	07	5117667-01/3	HANDLE,UPPER	1
	08	5149198-01/1	BOLT	2
	09	5140266-00/7	WASHER	2
	10	5137679-00/6	WING KNOB	2
	11	5117082-05/6	HANDLE,LOWER	1
	12	5149601-00/6	LABEL-WARNING	1
	13	5140423-00/4	PIN RETAINING	2
	14	5140092-03/1	PIVOT PIN	2
	15	5149277-00/5	BALL	1
	16	5127377-00/9	INDICATOR COVER	1
	17	5138491-00/5	GRASSBOX UPPER ASSY	1
	18	5106761-00/9	GRASSBOX SCREEN	1
	19	5106736-00/1	GRASSBOX LOWER	1
	20	5127397-00/7	COVER PLATE	1
	21	5117375-00/5	LEVER, HEIGHT OF CUT, L/H	1
	22	5127060-00/1	REAR ROLLER	2
	23	5137899-00/0	REAR AXLE	1
	24	5137484-00/1	HINGE PIN	1
	25	5106598-00/5	SAFETY FLAP	1
	26	5149600-00/8	SPRING	1
	27	5117375-01/3	LEVER, HEIGHT OF CUT, R/H	1
	28	5150009-00/8	MOTOR	1
	29	5106757-68/4	DECK	1
	30	5149437-00/5	WEIGHT	1
	31	5149598-00/4	AXLE CAP	2
	32	5140281-04/8	WASHER	4
	33	5127630-00/1	WHEEL	2
	34	5148738-00/7	SPRING	2
	35	5138486-00/5	AXLE	1
	36	5148122-01/2	SCREW	4
	37	5138447-00/7	FILTER	1
	38	5127599-00/8	FILTER HOLDER	1
	39	5126764-00/9	INSERT	1
	40	5118015-00/6	IMPELLER	1
	41	5126676-00/5	BLADE	1
	42	5148259-00/4	WASHER	1
	43	5137608-00/5	BLADE BOLT	1
	44	5126682-00/3	SPANNER/SCRAPER	1
	45	5127250-01/6	MAINS LEAD	1
	46	5127008-00/0	LOCK OFF	1
	47	5148658-00/7	SPRING,LOCK OFF	1
	48	5106728-01/6	SWITCHBOX UPPER	1
	49	5106481-01/2	LEVER	1
	50	5148657-00/9	SPRING,TORSION	1
	51	5137685-00/3	SWITCH	1
	52	5138384-00/2	PIN RETAINER	1
	53	5106538-00/1	SWITCHBOX LOWER	1
	54	5146672-00/0	SCREW	4
	55	5148814-07/1	LEAD	1