

MODEL	Micro Compact	PRODUCT APPLICATION
PRODUCT NO.	9633090	9633090-01 GB 9633090-86 A,B,D,E,F,I,NL,P,N,DK,S,SF.

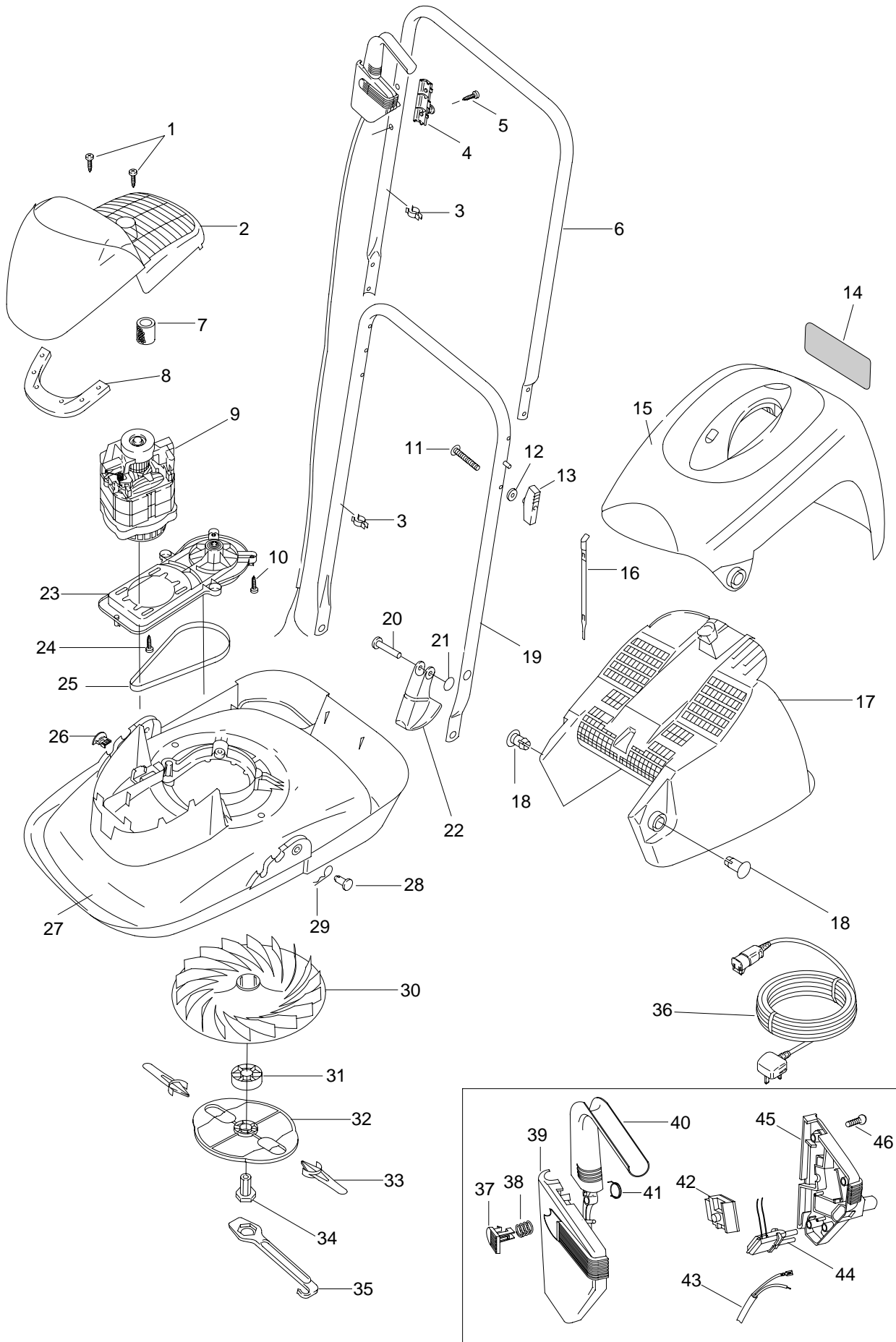

MODEL	Micro Compact	PRODUCT APPLICATION
PRODUCT NO.	9633090	9633090-01 GB 9633090-86 A,B,D,E,F,I,NL,P,N,DK,S,SF.



Key	Part Number	Description	Qty
01	5149117-00/3	SCREW	2
02	5106723-00/9	MOTOR COVER	1
03	5137750-00/5	CLIP CABLE	2
04	5118110-01/3	RETAINER	1
05	5146672-00/0	SCREW	2
06	5118082-00/6	HANDLE UPPER	1
07	5149539-00/5	FOAM SEAL	
08	5127560-00/0	FILTER	1
09	5150031-00/2	MOTOR	1
10	5149117-00/3	SCREW	3
11	5149198-01/1	BOLT	2
12	5140266-00/7	WASHER	2
13	5137679-00/6	WING KNOB	2
14	5138436-00/0	WARNING LABEL	1 GB
	5138438-00/6	WARNING LABEL	1 ABDEFINLPNDKSSF
15	5127555-00/0	GRASSBOX LID	1
16	5127580-00/8	GRASS BOX STRAP	1
17	5106724-00/7	GRASSBOX	1
18	5127556-00/8	PIN, LID FIX	2
19	5127590-00/7	HANDLE LOWER	1
20	5148506-03/2	CLEVIS PIN	1
21	5149344-00/3	WASHER,STARLOCK	1
22	5118097-00/4	LATCH - UPSTOP	1
23	5118226-00/9	BASEPLATE PULLEY ASSEMBLY	1
24	5148696-03/1	SCREW	4
25	5138435-00/2	BELT	1
26	5118081-00/8	RETAINER-CABLE	1
27	5106722-00/1	HOOD	1
28	5140092-03/1	PIVOT PIN	2
29	5140423-00/4	PIN RETAINING	2
30	5118095-00/8	IMPELLER	1
31	5138413-00/9	SPACER	1
32	5118080-00/0	DISC	1
33	5127557-00/6	BLADE	2
34	5138359-00/4	DISC NUT	1
35	5126682-00/3	SPANNER/SCRAPER	1
36	5127250-01/6	MAINS LEAD	1 GB
37	5127008-00/0	LOCK OFF	1
38	5148658-00/7	SPRING,LOCK OFF	1
39	5106728-01/6	SWITCHBOX UPPER	1
40	5106481-01/2	LEVER	1
41	5148657-00/9	SPRING,TORSION	1
42	5137685-00/3	SWITCH	1 GB
	5137786-00/9	SWITCH	1 ABDEFINLPNDKSSF
43	5148814-35/2	LEAD	1 GB
	5148814-36/0	LEAD	1 ABDEFINLPNDKSSF
44	5138384-00/2	PIN RETAINER	1 GB
	5148784-00/1	PIN RETAINER	1 ABDEFINLPNDKSSF
45	5106538-00/1	SWITCHBOX LOWER	1 GB
	5106540-00/7	SWITCHBOX LOWER	1 ABDEFINLPNDKSSF
46	5146672-00/0	SCREW	4