

Flymo

GTE (E47)-1.4 9635424

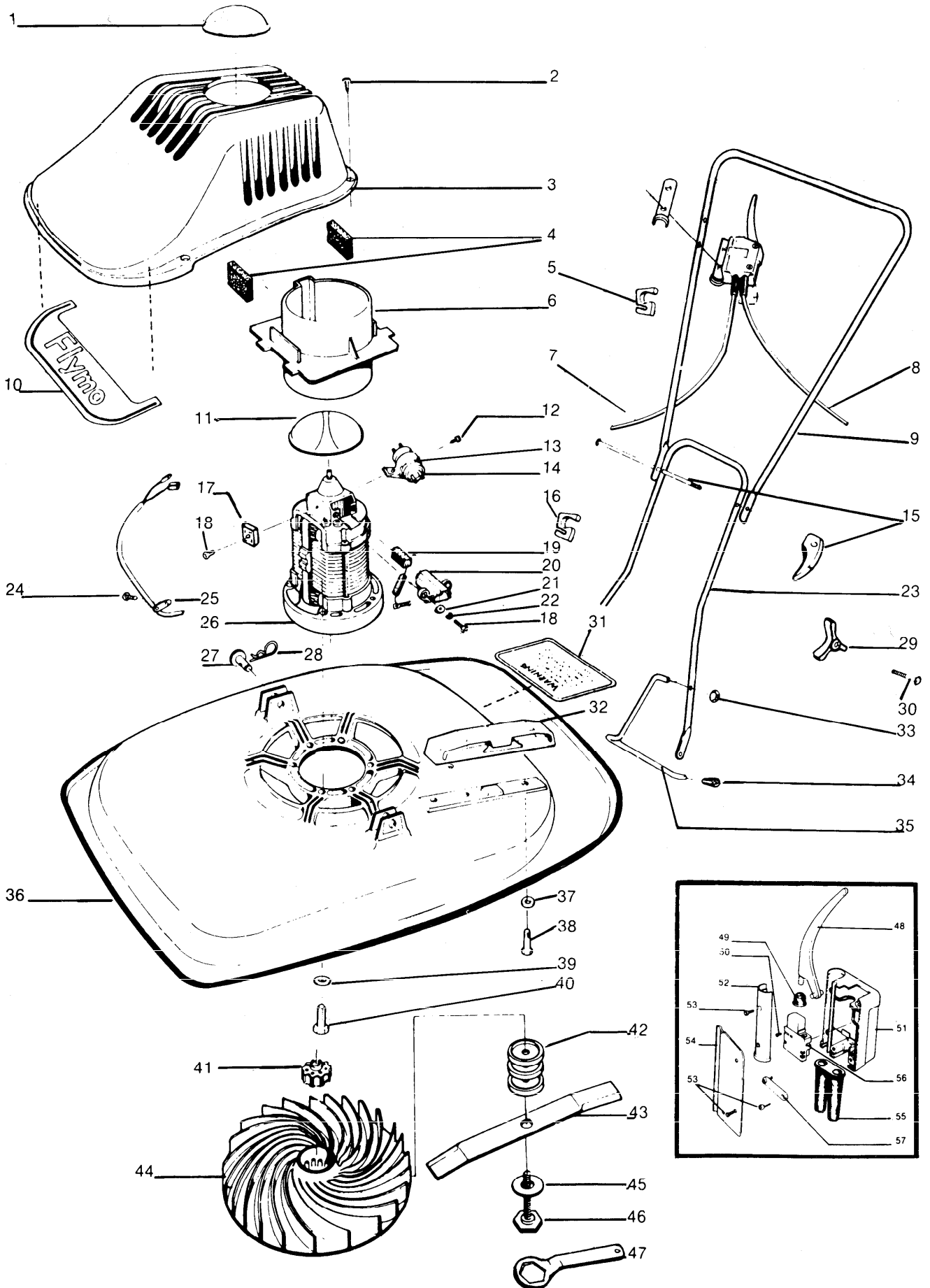



GTE (E47)-1.4 9635424

KEY No.	PART No.	DESCRIPTION	QUANTITY	COMMENTS APPLICATION	KEY No.	PART No.	DESCRIPTION	QUANTITY	COMMENTS APPLICATION
1	5126120-02/0	LENS	1		31	5146467-00/5	LABEL WARNING	1	GB.O/S.E.P.EI.
2	5146824-00/7	SCREW	4	ALT USE 5147665-00/4		5136507-00/0	LABEL WARNING	1	A.D.CH.
3	5126375-04/6	COWL ASSY C/W LENS	1			5146466-00/7	LABEL WARNING	1	N.DK.
4	5146628-00/2	FILTER	2			5136361-00/2	LABEL WARNING	1	SF.
5	5140482-00/0	CABLE CLIP SMALL	1			5146464-00/2	LABEL WARNING	1	B.F.N.
6	5116208-00/9	SUPPORT FILTER*	1			5146465-00/9	LABEL WARNING	1	SF.F.B.NL.
	5116423-00/4	SUPPORT FILTER	1			5146486-00/5	LABEL WARNING	1	I.
7	5147001-06/8	LEAD INTERNAL	1	GB.A.N.DK.F.B.NL.I.		5146516-00/9	LABEL WARNING	1	E.P.EI.O/S.
	5146989-01/6	LEAD INTERNAL	1	SF.		5146504-00/5	LABEL WARNING	1	S.
	5147001-13/4	LEAD INTERNAL	1	CH.		5147227-00/2	LABEL WARNING (ELCB)	1	S.
8	5147001-07/6	LEAD TERMINAL 15.24M*	1	GB.O/S.E.P.	32	5126210-00/3	GUIDE SLOTTED	1	
	5136621-00/9	LEAD TERMINAL C/W PLUG	1	GB.	33	5116682-00/9	STARLOCK WASHER	1	
	5147000-02/9	LEAD TERMINAL	1	A.N.DK.F.B.NL.I.	34	5146476-00/6	KNOB	1	
	5146475-08/1	LEAD TERMINAL	1	SF.	35	5126100-05/5	HOOK PLATED	1	
	5146361-03/4	LEAD TERMINAL C/W PLUG	1	D.	36	5106206-03/9	HOOD 47 CM	1	
	5147213-00/2	LEAD TERMINAL C/W ELCB	1	S.	37	5140943-00/1	WASHER	3	
	5147000-04/5	LEAD TERMINAL	1	CH.	38	5146824-00/7	SCREW	3	ALT USE 5147665-00/4
9	5126371-00/3	HANDLE UPPER 16mm	1	ALT USE 5126522-00/1	39	5146309-00/9	WASHER	6	
	5136573-01/0	HANDLE UPPER	1	D.	40	5141585-01/7	SCREW	6	
10	5116376-00/4	LABEL FLYMO	1	NLA USE 5126435-00/6	42	5126133-00/7	PINION IMPELLER	1	
11	5136241-00/6	DISC WARNING ASSY	1		42	5136240-01/6	BLADE SPACER	4	
12	7241287-40/3	SCREW 4mm	1		43	5126434-03/3	BLADE 47 CM	1	
13	323017-00/4	CLIP	1		44	5116197-01/2	IMPELLER	1	
14	323116-00/4	SUPPRESSOR & CLIP	1		45	5140516-00/5	ANTI FRICTION WASHER (PTFE)	1	
15	5136320-01/6	FOLDING MECHANISM	1	USE 5140690-00/8 AND 5140607-00/2	46	5136242-01/2	BLADE BOLT	1	
					47	5130127-00/3	SPANNER	1	
16	5140863-01/9	CABLE CLIP LARGE	1		48	5136182-01/0	LEVER SWITCH	1	
17	322814-00/5	RECTIFIER	1		49	5130406-01/9	SEAL CONE	1	
18	322482-00/1	SCREW M4 x 16mm	4		50	5141605-00/5	SCREW	4	
19	322824-00/4	CARBON BRUSH COMPLETE	2		51	5116346-05/6	SWITCHBOX BODY 16mm*	1	ALT USE 5116346-06/4
20	322819-00/4	BRUSH HOUSING COMPLETE	2			5116494-01/3	SWITCHBOX BODY 16mm	1	
21	29100-00/5	WASHER	4		52	5126290-00/5	SWITCHBOX RETAINER 16mm	1	
22	7351136-00/2	SPRING WASHER	4		53	5146672-00/0	SCREW GKN POLYMATE No. 6	6	
23	5116469-01/5	HANDLE LOWER	1		54	5116210-00/5	SWITCHBOX COVER*	1	
24	5146672-00/0	SCREW GKN POLYMATE No.6	2			5116495-00/2	SWITCHBOX COVER	1	
25	5140705-00/4	CABLE CLAMP	1		55	5141584-02/8	SLEEVE	1	
26	5116194-13/4	MOTOR 240 VOLT	1	NLA USE 5148040-00/8	56	5141586-14/8	SWITCH ON/OFF THERMAL CUT OUT	1	KOPP 2401-18
	5116194-14/2	MOTOR 220 VOLT	1	NLA USE 5148040-01/6	57	5146616-00/7	CLAMP CABLE	1	
27	5140092-01/5	PIN LOCKING	2	ALT USE 5140092-00/7					
28	5140423-00/4	PIN RETAINING	2						
29	5140690-00/8	KNOB WING	2						
	5140266-00/7	WASHER	2	NOT ILLUSTRATED					
30	5140607-00/2	BOLT HANDLE	2						

* Parts fitted to early manufactured models only.

PRODUCT VARIANT

9635424-03 A.	9635424-08 F.B.NL.	9635424-16 O/S.EI.P.E.	9635424-22 CH.
9635424-06 N.DK.	9635424-09 D.	9635424-21 S.	9635424-51 GB.
9635424-07 SF.	9635424-11 I.		

When no application details are shown the part applies to all countries.