

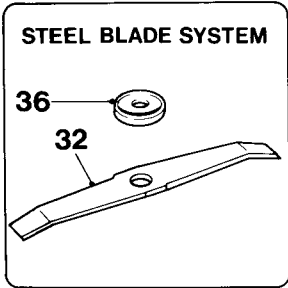

SPRINTER E30-11 TWIN 9633011
9633012

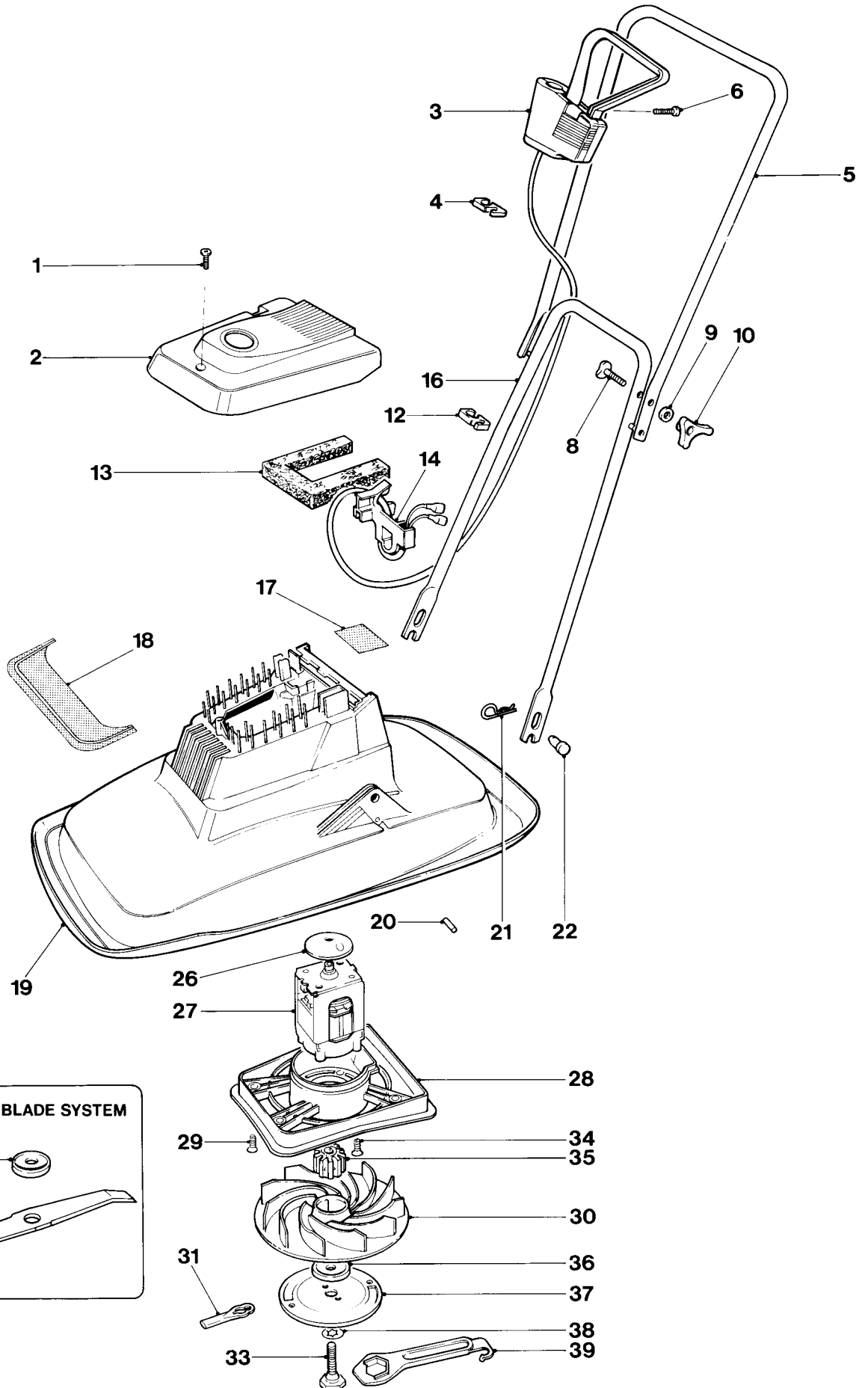

Flymo**SPRINTER E30-11 TWIN 9633011
9633012**

KEY No.	PART No	DESCRIPTION	QUANTITY	COMMENTS APPLICATION
1	5146736-00/3	SCREW HIGH/LOW	1	
2	5126821-02/3	COVER ASSY	1	
3	5126891-01/8	SWITCHBOX UNIVERSAL	1	
4	5140482-00/0	CABLE CLIP SMALL	1	
5	5126816-02/3	HANDLE/LABEL ASSY	1	
6	5146672-00/0	SCREW GKN POLYMATE	2	
8	5140607-00/2	BOLT HANDLE ¼ UNC x 45LG	2	
9	5140266-00/7	WASHER	2	
10	5140690-00/8	KNOB WING WHITE	2	
12	5140863-01/9	CABLE CLIP LARGE	1	
13	5137638-00/2	FILTER	1	
14	5126741-00/7	CLAMP PLASTIC	1	
16	5117082-00/7	HANDLE LOWER	1	
17	5146467-00/5	LABEL WARNING ELECTRIC	1	
18	5126885-00/2	LABEL FLYMO	1	
19	5126819-01/9	HOOD ASSY	1	
20	5147594-00/5	PIN	2	
21	5140423-00/4	PIN RETAINING	2	
22	5140092-00/7	PIVOT PIN	2	
26	5146469-01/9	WARNING DISC ASSY ORANGE	1	
27	5126608-01/6	MOTOR 240V SQUARE STACK	1	
	5126608-02/4	MOTOR 220V SQUARE STACK	1	EI.
28	5106279-00/2	MOTOR MOUNTING PLATE	1	
29	5146736-00/3	SCREW HIGH/LOW	4	
30	5116967-01/8	IMPELLER	1	
31	5148257-02/4	CUTTER PLASTIC LONG LIFE	2	
32	5126439-00/8	BLADE 30CM	1	
33	5137608-00/5	BLADE BOLT C/W PTFE WASHER	1	
34	5148122-01/2	SCREW PLASTITE 10 x 19MM LNG	4	
35	5126764-00/9	INSERT-PLASTIC	1	
36	5136240-01/6	BLADE SPACER	1	
37	5126734-01/0	DISC ASSY	1	
38	5148259-00/4	WASHER ANTI FRICTION PTFE	1	
39	5126682-00/3	SPANNER/SCRAPER ABS	1	

WHERE NO APPLICATION DETAILS ARE SHOWN, PART APPLIES TO ALL COUNTRIES

PRODUCT VARIANT

9633011-25 GB

9633012-18 EI