

MODEL	E30-7	PRODUCT APPLICATION 9633047-01 GB 9633047-86 D,DK,E,F,I,NL,P,S,SF	
PRODUCT NO.	9633047		

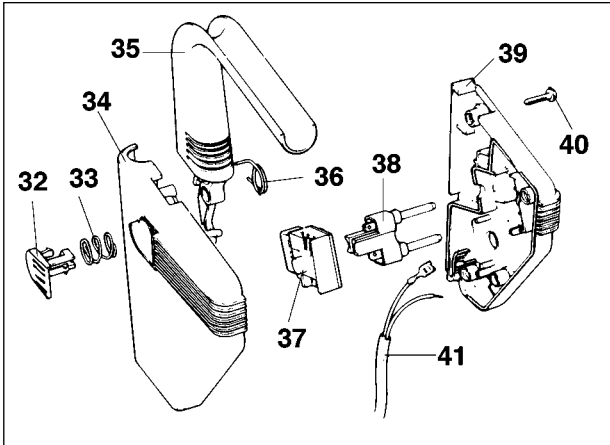

MODEL	E30-7	PRODUCT APPLICATION	
		9633047-01 GB	
PRODUCT NO.	9633047	9633047-86 D,DK,E,F,I,NL,P,S,SF	

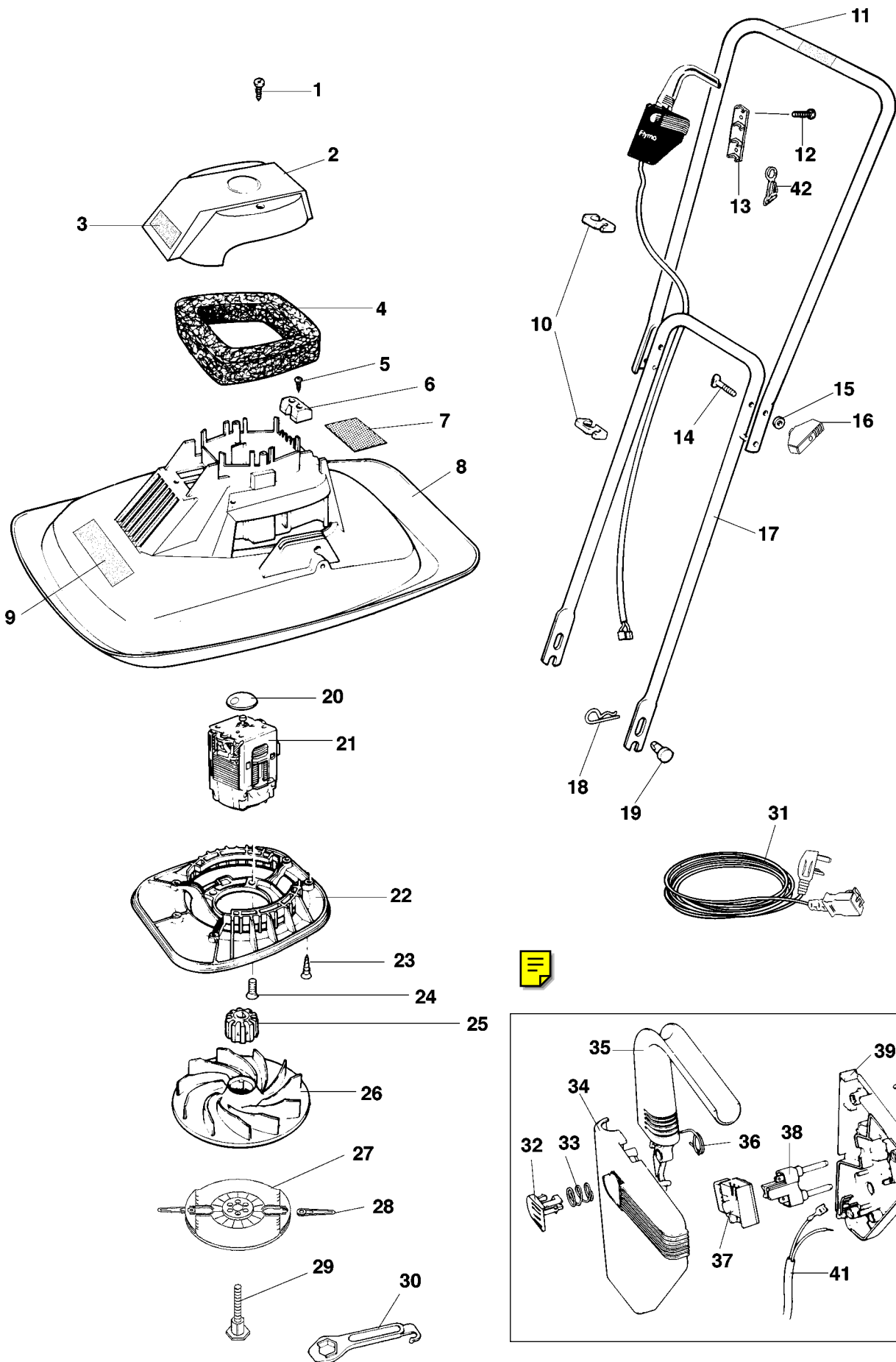

KEY PART NUMBER QTY

01	5146736-00/3	2		SCREW
02	5137988-02/7	1		MOTOR SHROUD ASSY
03	5148810-01/2	1		LABEL:E30
04	5136656-00/5	1		FILTER
05	5146736-00/3	2		SCREW
06	5126827-00/4	1		CABLE CLAMP
07	5146467-00/5	1	GB,EI	LABEL,WARNING
	5138422-01/8	1	F,NL,I,E,D,P	LABEL WARNING
	5138426-01/9	1	S,DK,SF	LABEL WARNING
08	5126515-02/1	1		HOOD
09	5136725-01/6	1		LABEL FLYMO
10	5137750-00/5	2		CLIP CABLE
11	5126816-20/5	1		HANDLE UPPER
12	5146672-00/0	2		SCREW
13	5117657-01/4	1		RETAINER,SWITCHBOX
14	5148672-00/8	2		BOLT,HANDLE
15	5140266-00/7	2		WASHER
16	5137679-00/6	2		WING KNOB
17	5117690-01/5	1		HANDLE,LOWER
18	5140423-00/4	2		PIN RETAINING
19	5140092-03/1	2		PIVOT PIN
20	5146469-01/9	1		WARNING DISC
21	5150008-00/0	1		MOTOR KS4642/125
22	5106169-01/3	1		MOTOR MOUNTING PLATE
23	5146736-00/3	5		SCREW
24	5148122-01/2	4		SCREW
25	5126764-00/9	1		INSERT,IMPELLER
26	5117084-02/9	1		IMPELLER
27	5106669-00/4	1		CUTTER DISC
28	5127500-00/6	2		PLASTIC CUTTER
29	5127506-00/3	1		BLADE BOLT
30	5126682-00/3	1		SPANNER/SCRAPER
31	5127250-03/2	1	GB,EI	LEAD
32	5127008-00/0	1		LOCK OFF
33	5148658-00/7	1		SPRING
34	5106539-01/7	1		SWITCHBOX UPPER
35	5106481-01/2	1		LEVER
36	5148657-00/9	1		SPRING
37	5137685-00/3	1		SWITCH
38	5137686-00/1	1		PIN RETAINER
39	5106538-00/1	1	GB,EI	SWITCHBOX LOWER
	5106540-00/7	1	F,NL,I,E,D,P,S,DK,SF	
40	5146672-00/0	4		SCREW
41	5148814-11/3	1		LEAD