

Flymo

DLE-2 9635126
DLE-2 'S' 9635128

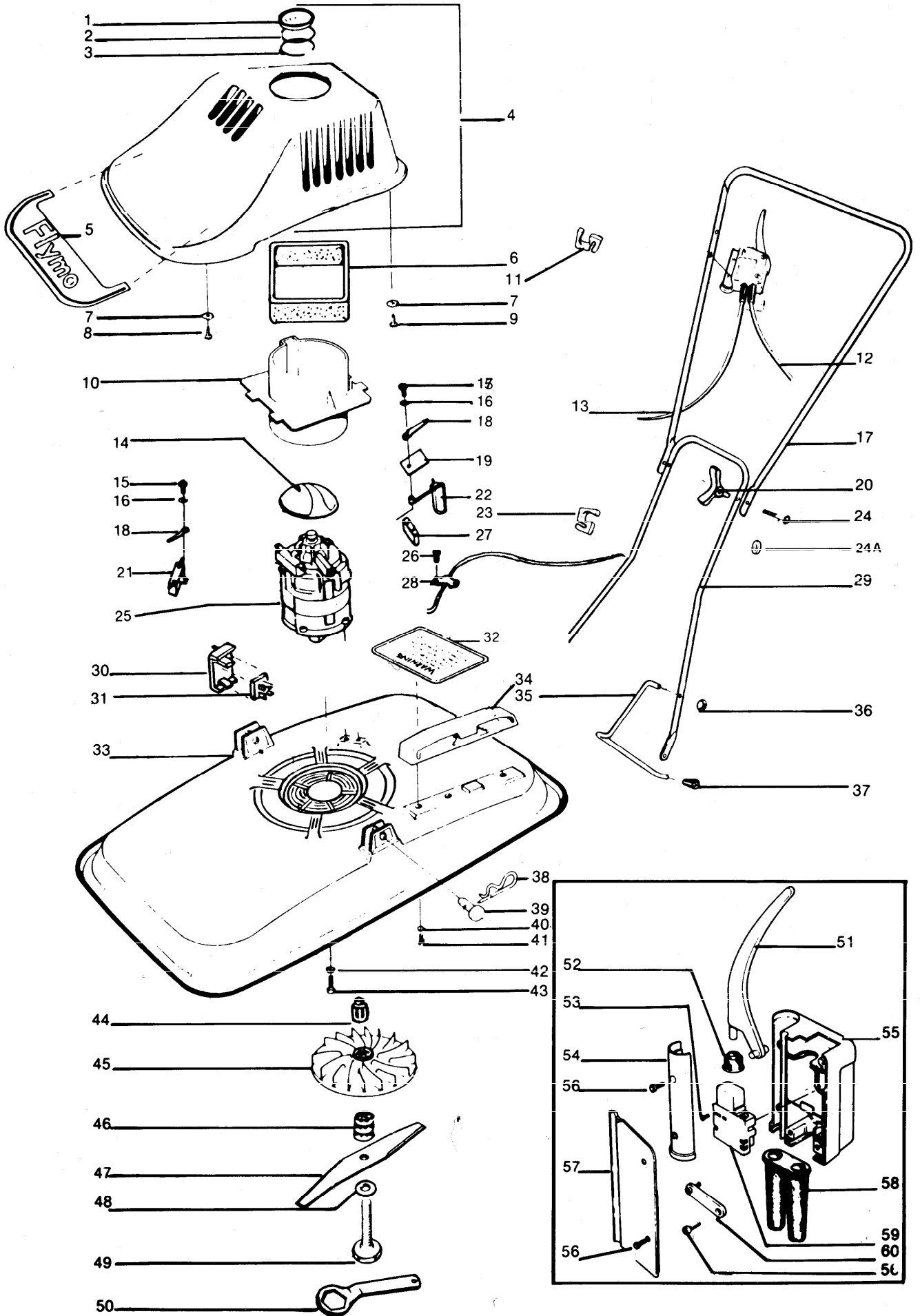

Flymo[®]
DLE-2 9635126
DLE-2 'S' 9635128

KEY No.	PART No.	DESCRIPTION	QUANTITY	COMMENTS/ APPLICATION	KEY No.	PART No.	DESCRIPTION	QUANTITY	COMMENTS/ APPLICATION
1	5140288-00/1	LENS	1		31	322814-00/5	RECTIFIER	1	DLE 'S' ONLY
2	5140302-00/0	SEAL	1		32	5146467-00/5	LABEL WARNING	1	GB.
3	5140303-00/8	RING	1			5136507-00/0	LABEL WARNING	1	D.CH.A.
4	5116171-00/9	COWLING ASSY	1			5136364-00/6	LABEL WARNING	1	N.
5	5126598-00/1	LABEL FLYMO	1			5146466-00/7	LABEL WARNING	1	N.DK.
6	5146580-00/5	FILTER	1			5136361-00/2	LABEL WARNING	1	SF.
7	5140266-00/7	WASHER	4	NO LONGER FITTED		5146464-00/2	LABEL WARNING	1	F.B.NL.CH.
8	5146731-00/4	SCREW	2			5146486-00/5	LABEL WARNING	1	I.
9	5146045-02/5	SCREW	1			5146516-00/9	LABEL WARNING	1	E.P.EI.O.S.
10	5116167-00/7	SUPPORT FILTER	1			5146504-00/5	LABEL WARNING	1	S.
11	5140482-00/0	CABLE CLIP SMALL	1			5147227-00/2	LABEL WARNING (ELCB)	1	S.
12	5147001-07/6	LEAD TERMINAL 15.24M	1	DLE 'S' ONLY	33	5106051-01/3	HOOD	1	
	5147000-01/1	LEAD TERMINAL .5M	1		34	5126210-00/3	GUIDE SLOTTED	1	
	5146475-08/1	LEAD TERMINAL	1	SF.	35	5126100-05/5	HOOK PLATED	1	
	5146361-03/4	LEAD TERMINAL C/W PLUG	1	D.	36	5146682-00/9	STARLOCK WASHER	1	
	5147213-00/2	LEAD TERMINAL C/W ELCB	1	S.	37	5146476-00/6	KNOB	1	
	5147000-03/7	LEAD TERMINAL .5M	1	CH.	38	5140423-00/4	PIN RETAINING	2	
13	5147001-01/9	LEAD INTERNAL	1		39	5140092-01/5	PIN LOCKING	2	ALT USE 5140092-00/7
	5146989-03/2	LEAD INTERNAL	1	SF.	40	5140943-00/1	WASHER	3	
	5147001-02/7	LEAD INTERNAL	1	D.	41	5146824-00/7	SCREW	3	ALT USE 5147665-00/4
	5147001-12/6	LEAD INTERNAL	1	CH.	42	5140266-00/7	WASHER	3	
14	5146469-00/1	WARNING DISC	1	ALT USE 5146469-01/9	43	5141585-01/7	SCREW	3	
15	7241293-61/7	SCREW THREAD FORMING	2		44	5136297-00/8	INSERT	1	
16	7352136-51/4	LOCKWASHER	2		45	5116375-01/4	IMPELLER	1	
17	5126242-03/0	HANDLE UPPER	1		46	5136240-01/6	BLADE SPACER	3	
	5136573-02/8	HANDLE CORD GUIDE ASSY	1	D.	47	5126439-00/8	BLADE 30 CM	1	
18	113721-00/5	CLIP	2		48	5140516-00/5	ANTI FRICTION WASHER (PTFE)	1	
19	4000830-00/2	INSULATING TAB	1	NO LONGER FITTED	49	5136242-01/2	BLADE BOLT	1	
20	5140690-00/8	KNOB WING	2		50	5130127-00/3	SPANNER	1	
21	113030-01/9	SUPPRESSOR 0.15 MF	1		51	5136182-01/0	LEVER SWITCH	1	
	322876-00/4	NYLON TIE	1	NOT ILLUSTRATED	52	5130406-01/9	SEAL CONE	1	
22	7629125-07/6	TAB STRIP	1		53	5141605-00/5	SCREW	4	
23	5140863-01/9	CABLE CLIP LARGE	1		54	5126167-00/5	SWITCHBOX RETAINER 16mm*	1	
24	5140607-00/2	BOLT HANDLE	2		55	5116346-05/6	SWITCHBOX BODY 16mm*	1	ALT USE 5116346-06/4
24A	5140266-00/7	WASHER	2			5116494-01/3	SWITCHBOX BODY 16mm	1	
25	5126433-01/9	MOTOR 240 VOLT	1		56	5146672-00/0	SCREW GKN POLYMATE NO. 6	6	
	5126354-01/7	MOTOR 240 VOLT	1	DLE 'S' ONLY	57	5116210-00/5	SWITCHBOX COVER*	1	
	5126433-02/7	MOTOR 220 VOLT	1			5116495-00/2	SWITCHBOX COVER	1	
	5126354-02/5	MOTOR 220 VOLT	1	DLE 'S' ONLY	58	5141584-02/8	SLEEVE	1	
26	5147025-00/0	SCREW	2		59	5141586-15/5	SWITCH ON/OFF THERMAL CUT OUT	1	KOPP 2401-13
27	113030-01/9	SUPPRESSOR 0.15 MF	1		60	5146616-00/7	CLAMP CABLE	1	
28	5140705-00/4	CABLE CLAMP	1						
29	5126316-00/8	HANDLE LOWER	1	ALT USE 5126394-00/5					
30	5136441-00/2	BRACKET	1	DLE 'S' ONLY					

* Compatible parts fitted to early manufactured models only.

PRODUCT VARIANT

9635126-01 GB.	9635126-09 D.	9635128-01 GB.	9635128-09 D.
9635126-03 A.	9635126-11 I.	9635128-03 A.	9635128-11 I.
9635126-06 DK.N.	9635126-16 O/S.E.P.IE.	9635128-06 DK.N.	9635128-16 O/S.E.P.IE.
9635126-07 SF.	9635126-21 S.	9635128-07 SF.	9635128-22 CH.
9635126-08 NL.F.B.	9635126-22 CH.	9635128-08 NL.F.B.	