

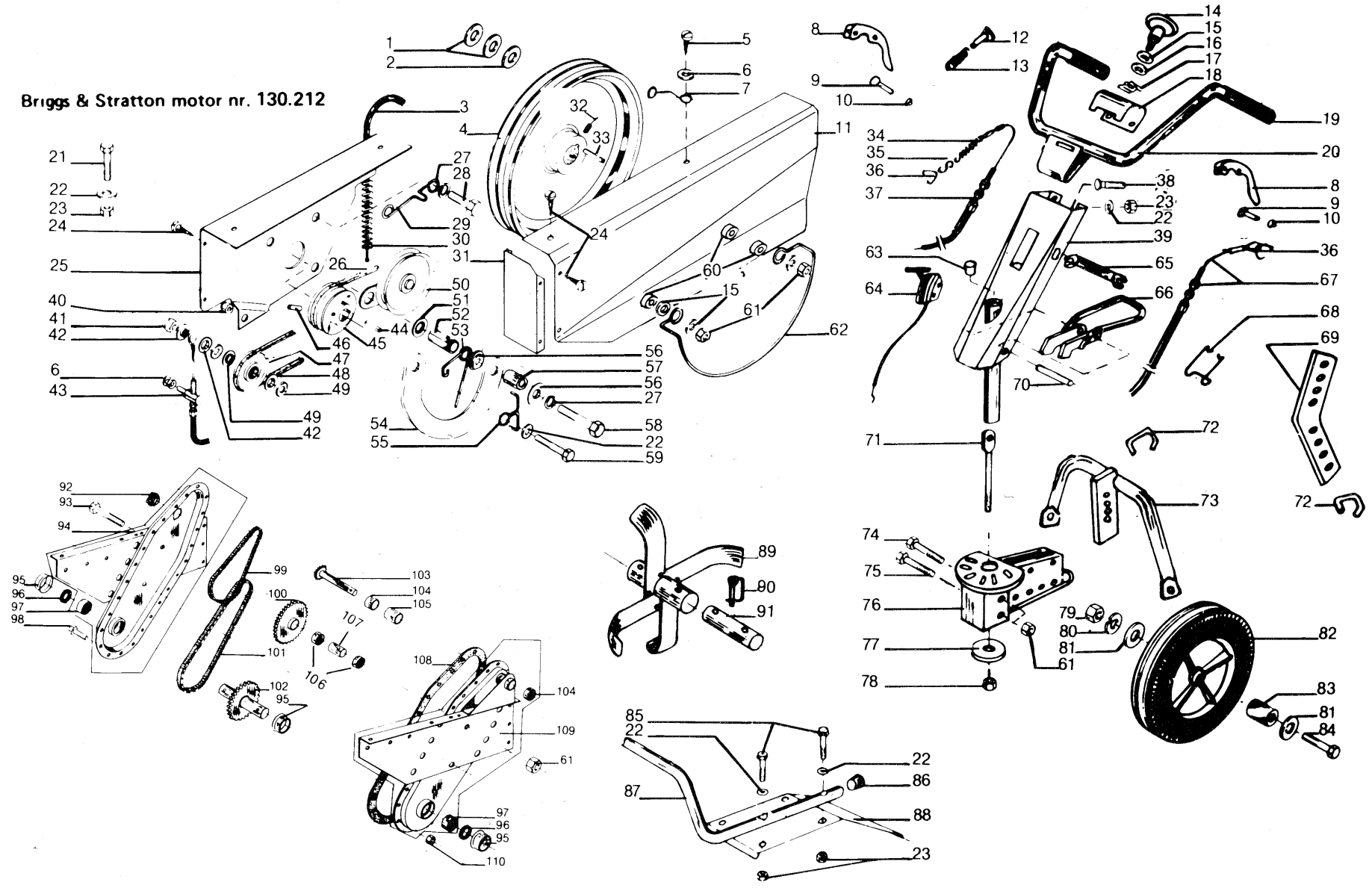

GLM 9647350

KEY No.	PART No.	DESCRIPTION	QUANTITY	COMMENTS/ APPLICATION	KEY No.	PART No.	DESCRIPTION	QUANTITY	COMMENTS/ APPLICATION
1	515700840-00/9	BOLT	1		48	51512427-00/6	TENSIONER	1	
2	515768012-00/4	WASHER BASE	2		49	515139764-00/2	WASHER	1	
3	515763008-00/7	NUT LOCK	3		50	515105110-00/8	SPACER	1	
4	515140499-00/2	STONE GUARD	1		51	515123205-00/4	SCREW	1	
5	515202138-00/1	THROTTLE CONTROL COMPLETE	1		52	9971017-10/9	TINE SINGLE	2	
6	515745035-00/3	SCREW	2		53	9971005-10/4	TINE SINGLE	2	ALT USE 515212953-00/1
7	515105605-00/7	HANDLE UPPER	1		54	515500324-00/6	ROTOR PIN	4	
8	515105556-00/2	HANDLE LOWER RIGHT	1		55	515104136-00/4	PLUG OIL	1	
9	515104121-00/6	GRIP PLASTIC	2		56	515700070-00/3	BOLT	1	
10	515120043-00/2	PIN LOCK-OFF	1		57	515211481-00/4	CHAIN CASE R/H	1	
11	515118193-00/9	SPRING	1		58	515138717-00/1	GASKET	3	
12	515138675-00/1	BRACKET MOUNTING	1		59	515115045-00/4	SEAL	2	
13	515116058-00/6	SNAP RING	1		60	515109039-00/5	BEARING NEEDLE	2	
14	515118169-00/9	HOOK COUPLING	1		61	515701612-00/1	BOLT	33	
15	515711840-00/6	BOLT LOCK	2		62	515113011-00/8	CHAIN C/W LINK	1	
16	515105557-00/0	HANDLE LOWER LEFT	1		63	515212246-00/0	SPROCKET	1	
17	515139761-00/8	LEVER CLUTCH	1		64	515113009-00/2	CHAIN C/W LINK	1	
18	515120074-00/7	PIN	1		65	515212243-00/7	SPROCKET	1	
19	515118194-00/7	SPRING	1		66	515213240-00/2	PULLEY AXLE	1	
20	515118358-00/8	HOOK-S	1		67	515213565-00/2	AXLE	1	
21	515213205-00/5	CABLE CLUTCH	1		68	515108021-00/4	BEARING	2	
22	515118194-00/7	SPRING	1		69	515105154-00/6	BUSH	1	
23	515139767-00/5	WASHER	2		70	515109040-00/3	BEARING	2	
24	515796016-00/1	WASHER	1		71	515105487-00/0	SPACER	1	
25	515120075-00/4	PIN	1		72	515211482-00/2	CHAIN CASE L/H	1	
26	515700075-00/2	BOLT	1		73	515115042-00/1	GASKET	1	
27	515791025-00/7	SCREW	1		74	515763006-00/1	NUT	33	
28	515213449-00/9	SPROCKET	1						
29	515763010-00/3	NUT	3						
30	515118187-00/1	SPRING	1						
31	515213892-00/0	ARRESTER BAR	1						
32	515120076-00/2	ARRESTER BOLT	1						
33	515212417-00/7	PULLEY	1						
34	515739810-00/7	SCREW GRUB	1						
35	515118433-00/9	SPRING	1						
36	515118336-00/4	CABLE GUIDE	1						
37	515137411-00/2	ENGINE PULLEY	1						
38	515117009-00/8	KEY	1						
39	515112010-00/1	BELT	1						
40	515790004-00/3	SCREW SET	2						
41	515140171-00/7	BELT COVER	1						
42	515768014-00/0	WASHER	2						
43	515202604-00/2	WHEEL ASSY	2						
44	515116040-00/4	LOCK WASHER	2						
45	515300275-00/2	BRACKET	1						
46	515772009-00/4	WASHER SPRING	2						
47	515123201-00/3	BOLT	1						

Briggs & Stratton motor nr. 130.212





GLM 9647351

KEY No.	PART No.	DESCRIPTION	QUANTITY	COMMENTS/ APPLICATION	KEY No.	PART No.	DESCRIPTION	QUANTITY	COMMENTS/ APPLICATION
1	515139767-00/5	WASHER	2						
2	515796016-00/1	WASHER	1		62	515118382-00/8	BELT GUIDE	1	
3	515202115-00/9	FORWARD DRIVE CABLE	1	MODEL 501669	63	515104479-00/8	PLUG	1	
3A	515202135-00/7	FORWARD DRIVE CABLE	1	MODEL 501772	64	515202116-00/7	THROTTLE CONTROL	1	
4	515213624-00/7	PULLEY	1		65	515107177-00/5	SHAFT	1	MODEL 501669
5	515745031-00/2	SCREW	1		65A	515107259-00/1	BRACKET	1	MODEL 501772
6	515768010-00/8	WASHER	3		66	515213281-00/6	PEDAL	1	
7	515118433-00/9	SPRING	1		67	515202114-00/2	REVERSE DRIVE CABLE	1	MODEL 501669
8	515139761-00/8	LEVER CLUTCH	2		67A	515202134-00/0	REVERSE DRIVE CABLE	1	MODEL 501772
9	515120074-00/7	PIN	2		68	515118330-00/7	SPRING PEDAL	1	
10	515116058-00/6	SNAP RING	2		69	515135164-00/9	ARRESTER BAR	1	
11	515140696-00/3	COVER BELT	1		70	515107180-00/9	SHAFT	1	
12	515120043-00/2	PIN LOCK-OFF	1		71	515790022-00/5	BOLT TENSION	1	
13	515118193-00/9	SPRING	1		72	515137366-00/8	BOLT ARRESTER BAR	2	NLA USE 515118587-00/2 SPRING AND 5169069-00/1 BOLT
14	515213584-00/3	SCREW HANDLE LOCKING	1						
15	515768013-00/2	WASHER BASE	4		73	515212799-00/8	TRANSPORT WHEEL BRACKET	1	
16	515118457-00/8	WASHER SPRING	1		74	515700090-00/1	BOLT	1	
17	515796011-00/2	WASHER	1		75	515700065-00/3	BOLT	1	
18	515139625-00/5	LOCK PLATE	1		76	515213284-00/0	HANDLE COLUMN LOWER	1	
19	515104121-00/6	GRIP PLASTIC	2		77	515118343-00/0	SPRING DISC	1	
20	515213580-00/1	HANDLE UPPER	1		78	515763012-00/9	NUT	1	
21	515700840-00/9	BOLT	1		79	515756010-00/2	NUT	2	
22	515768012-00/4	WASHER BASE	5		80	515772012-00/8	WASHER SPRING	2	
23	515763008-00/7	NUT LOCK	4		81	515796002-00/1	WASHER	4	
24	515745030-00/4	SCREW	5		82	515202593-00/7	WHEEL ASSY	2	
25	515140697-00/1	PLATE REAR	1		83	515105254-00/4	SPACER	2	
26	515112047-00/3	FORWARD DRIVE BELT	1		84	515700075-00/2	BOLT	2	
27	515772009-00/4	WASHER SPRING	2		85	515700830-00/0	SCREW	2	MODEL 501669
28	515123201-00/3	BOLT	1		85A	515701830-00/9	SCREW	2	MODEL 501772
29	515118388-00/5	SPRING	1		86	515104457-00/4	FERRULE PLASTIC	1	
30	515118389-00/3	SPRING	1		87	515105574-00/5	PROTECTION BAR	1	MODEL 501669
31	515139698-00/2	COVER BELT	2		87A	515105691-00/7	PROTECTION BAR	1	MODEL 501772
32	515739810-00/7	SCREW GRUB	1		88	515140499-00/2	STONE GUARD	1	
33	515117009-00/8	KEY	1		89	9971005-10/4	TINE	4	SINGLE ALT USE 515212953-00/1
34	515118359-00/6	SPRING	1	MODEL 501669					
34A	515118194-00/7	SPRING	1	MODEL 501772	90	9971013-10/8	TINE PIN	8	NLA USE 9971013-10/8
35	515118358-00/8	HOOK-S	1		91	515101510-00/3	SHAFT EXT (PAIRS)	2	
36	515118169-00/9	HOOK COUPLING	1		92	515104136-00/4	PLUG OIL	1	
37	515202115-00/9	FORWARD DRIVE CABLE	1	MODEL 501669	93	515700080-00/2	BOLT (SHAFT)	1	
37A	515202135-00/7	FORWARD DRIVE CABLE	1	MODEL 501772	94	515213091-00/9	CHAIN CASE HOUSING RIGHT	1	MODEL 501669 NLA SPECIAL ORDER
38	515711820-00/8	SCREW LOCK	1		94A	515211479-00/8	CHAIN CASE HOUSING RIGHT	1	MODEL 501772
39	515213286-00/5	HANDLE COLUMN	1	MODEL 501669 NLA SPECIAL ORDER	95	515138717-00/1	GASKET	3	
39A	515213893-00/8	HANDLE COLUMN	1	MODEL 501772	96	515115045-00/4	SEAL	2	
40	515762006-00/2	NUT	1		97	515109039-00/5	BEARING NEEDLE	2	
41	515762008-00/8	NUT NYLOCK	1		98	515701612-00/1	BOLT	25	
42	515139754-00/3	WASHER (SPACER)	4		99	515113011-00/8	CHAIN C/W LINK	1	
43	515202114-00/2	REVERSE DRIVE CABLE	1	MODEL 501669	100	515212246-00/0	SPROCKET	1	
43A	515202134-00/0	REVERSE DRIVE CABLE	1	MODEL 501772	101	515113009-00/2	CHAIN C/W LINK	1	
44	515117009-00/8	KEY	1		102	515212243-00/7	SPROCKET	1	
45	515137407-00/0	PULLEY DRIVE	1		103	515213240-00/2	PULLEY AXLE	1	
46	515739610-00/1	SCREW GRUB	1		104	515108021-00/4	BEARING	2	
47	515212168-00/6	TENSION PULLEY	1		105	515105154-00/6	BUSH	1	
48	515112044-00/0	REVERSE DRIVE BELT	1		106	515109040-00/3	BEARING	1	
49	515796009-00/6	WASHER	2		107	515105487-00/0	SPACER	1	
50	515213860-00/7	PULLEY TENSION	1		108	515115042-00/1	GASKET	1	
51	515139764-00/2	WASHER	1		109	515213090-00/1	CHAIN CASE HOUSING LEFT	1	MODEL 501669 NLA SPECIAL ORDER
52	515105519-00/0	BUSH	1						MODEL 501772
53	515118380-00/2	SPRING	1		109A	515211478-00/0	CHAIN CASE HOUSING LEFT	1	MODEL 501772
54	515139822-00/8	LEVER	1		110	515763006-00/1	NUT	25	
55	515118381-00/0	GUIDE BELT	1		111	515211414-00/5	CHAIN CASE COMPLETE	1	NOT ILLUSTRATED MODEL 501669
56	515796024-00/5	WASHER	2						NOT ILLUSTRATED MODEL 501772
57	515105648-00/7	BUSH	1		111A	515211587-00/8	CHAIN CASE COMPLETE	1	NLA SPECIAL ORDER
58	515123209-00/6	BOLT	1						
59	515700850-00/8	BOLT	1						
60	515105376-00/5	SPACER	3						
61	515763010-00/3	NUT	6						

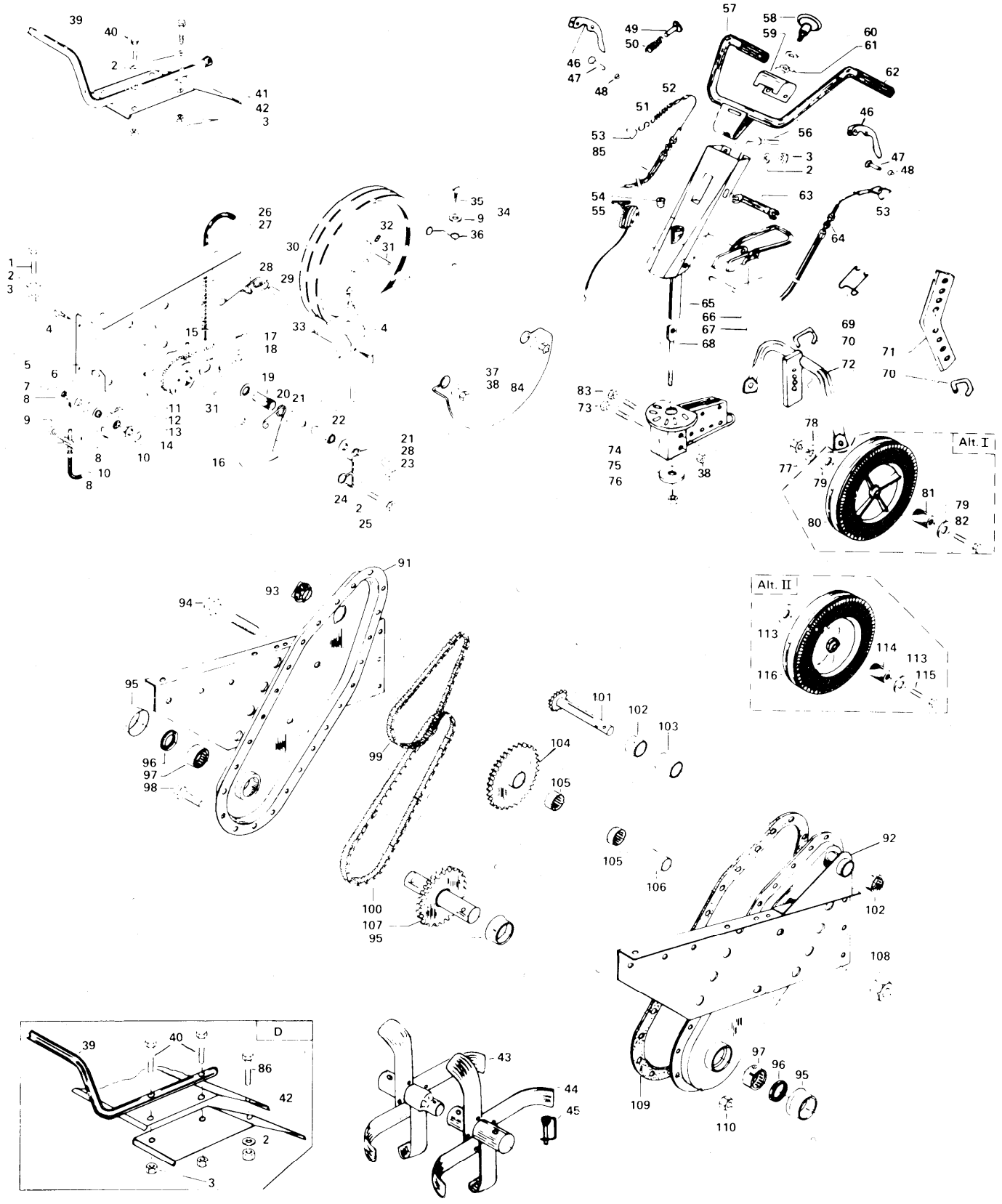



GLM 9953600

KEY No.	PART No.	DESCRIPTION	QUANTITY	COMMENTS/ APPLICATION	KEY No.	PART No.	DESCRIPTION	QUANTITY	COMMENTS/ APPLICATION
1	515700840-00/9	BOLT	4		59	515139625-00/5	LOCK PLATE	1	
2	515768012-00/4	WASHER BASE	5		60	515118457-00/8	WASHER SPRING	1	
3	515763008-00/7	NUT LOCK	3		61	515796011-00/2	WASHER	1	
4	515745030-00/4	SCREW	4		62	515104121-00/6	GRIP PLASTIC	2	
5	515140697-00/1	PLATE REAR	1		63	515107259-00/1	BRACKET	1	
6	515762006-00/2	NUT	1		64	515202134-00/0	REVERSE DRIVE CABLE	1	
7	515762008-00/8	NUT NYLOCK	1		65	515213893-00/8	HANDLE COLUMN	1	
8	515139754-00/3	WASHER (SPACER)	3		66	515107180-00/9	SHAFT	1	
9	515768010-00/8	WASHER	1		67	515213281-00/6	PEDAL	1	
10	515796009-00/6	WASHER	2		68	515790022-00/5	BOLT TENSION	1	
11	515137407-00/0	PULLEY DRIVE	1		69	515118330-00/7	SPRING PEDAL	1	
12	515739610-00/1	SCREW GRUB	2		70	515137366-00/8	BOLT ARRESTER BAR	1	NLA USE 515118587-00/2 SPRING AND 5169069-00/1 BOLT
13	515212168-00/6	TENSION PULLEY	1						
14	515112044-00/0	BELT	1	REVERSE DRIVE	71	515135165-00/6	DEPTH SKID	1	
15	515112047-00/3	BELT	1	FORWARD DRIVE	72	515212799-00/8	TRANSPORT WHEEL BRACKET	1	
16	515139822-00/8	LEVER	1		73	515700065-00/3	BOLT	1	
17	515213860-00/7	PULLEY TENSION	1		74	515213284-00/0	HANDLE COLUMN LOWER	1	
18	515139764-00/2	WASHER	1		75	515118343-00/0	SPRING DISC	1	
19	515105519-00/0	BUSH	1		76	515763012-00/9	NUT	1	
20	515118380-00/2	SPRING	1		77	515756010-00/2	NUT	2	
21	515796024-00/5	WASHER	2		78	515772012-00/8	WASHER SPRING	2	
22	515105648-00/7	BUSH	1		79	515796002-00/1	WASHER	4	
23	515123209-00/6	BOLT	1		80	515202593-00/7	WHEEL ASSY	2	
24	515118381-00/0	GUIDE BELT	1		81	515105254-00/4	SPACER	2	
25	515700850-00/8	BOLT	1		82	515700080-00/2	BOLT (SHAFT)	1	
26	515118389-00/3	SPRING	1		83	515700075-00/2	BOLT	1	
27	515118388-00/5	SPRING	1		84	515118505-00/4	BELT GUIDE	1	
28	515772009-00/4	WASHER SPRING	2		85	515202135-00/7	FORWARD DRIVE CABLE	1	
29	515123201-00/3	BOLT	2		86	515701816-00/8	BOLT	2	
30	515213998-00/5	PULLEY	1		90	5157760-00/7	CHAIN CASE COMPLETE	1	NOT ILLUSTRATED
31	515117009-00/8	KEY	1		91	515211479-00/8	CHAIN CASE HOUSING RIGHT	1	
32	515739810-00/7	SCREW GRUB	1		92	515211478-00/0	CHAIN CASE HOUSING LEFT	1	
33	515139698-00/2	COVER BELT	1		93	515104136-00/4	PLUG OIL	1	
34	515140696-00/3	COVER BELT	1		94	515700080-00/2	BOLT (SHAFT)	1	
35	515745031-00/2	SCREW	1		95	515139946-00/5	SEAL	3	
36	515118433-00/9	SPRING	1		96	515115045-00/4	SEAL	2	
37	515768013-00/2	WASHER BASE	2		97	515109039-00/5	BEARING NEEDLE	2	
38	515763010-00/3	NUT	2		98	515701612-00/1	BOLT	25	
39	515105691-00/7	PROTECTION BAR	1		99	515113011-00/8	CHAIN C/W LINK	1	
40	515701830-00/9	SCREW	4		100	515113009-00/2	CHAIN C/W LINK	1	
41	515104457-00/4	FERRULE PLASTIC	1		101	515213997-00/7	SHAFT	1	
42	515140499-00/2	STONE GUARD	2		102	515108021-00/4	BEARING	2	
43	9971017-10/9	TINE	2	SINGLE	103	515105154-00/6	BUSH	1	
44	9971005-10/4	TINE	2	SINGLE ALT USE 515212953-00/1 NLA USE 9971013-10/8	104	515211480-00/6	SPROCKET ASSY	1	
45	9971013-10/8	TINE PIN	6		105	515109040-00/3	BEARING	2	
46	515139761-00/8	LEVER CLUTCH	2		106	515105487-00/0	SPACER	1	
47	515120074-00/7	PIN	2		107	515212243-00/7	SPROCKET	1	
48	515116058-00/6	SNAP RING	2		108	515763010-00/3	NUT	1	
49	515120043-00/2	PIN LOCK-OFF	1		109	515115042-00/1	GASKET	1	
50	515118193-00/9	SPRING	1		110	515763006-00/1	NUT	25	
51	515118358-00/8	HOOK-S	1		113	515768013-00/2	WASHER BASE	4	
52	515118194-00/7	SPRING	1		114	515105542-00/2	BUSH	2	
53	515118169-00/9	HOOK COUPLING	2		115	515700060-00/4	SCREW	2	
54	515104479-00/8	PLUG	1		116	515202532-00/5	WHEEL ASSY	2	
55	515202112-00/6	THROTTLE CONTROL COMPLETE	1	NLA USE 515202116-00/7					
56	515711820-00/8	SCREW LOCK	2						
57	515213580-00/1	HANDLE UPPER	1						
58	515213584-00/3	SCREW HANDLE LOCKING	1						

PRODUCT VARIANT

9953600-01 GB.