

# Flymo

Multi-trim 250-4 9648511

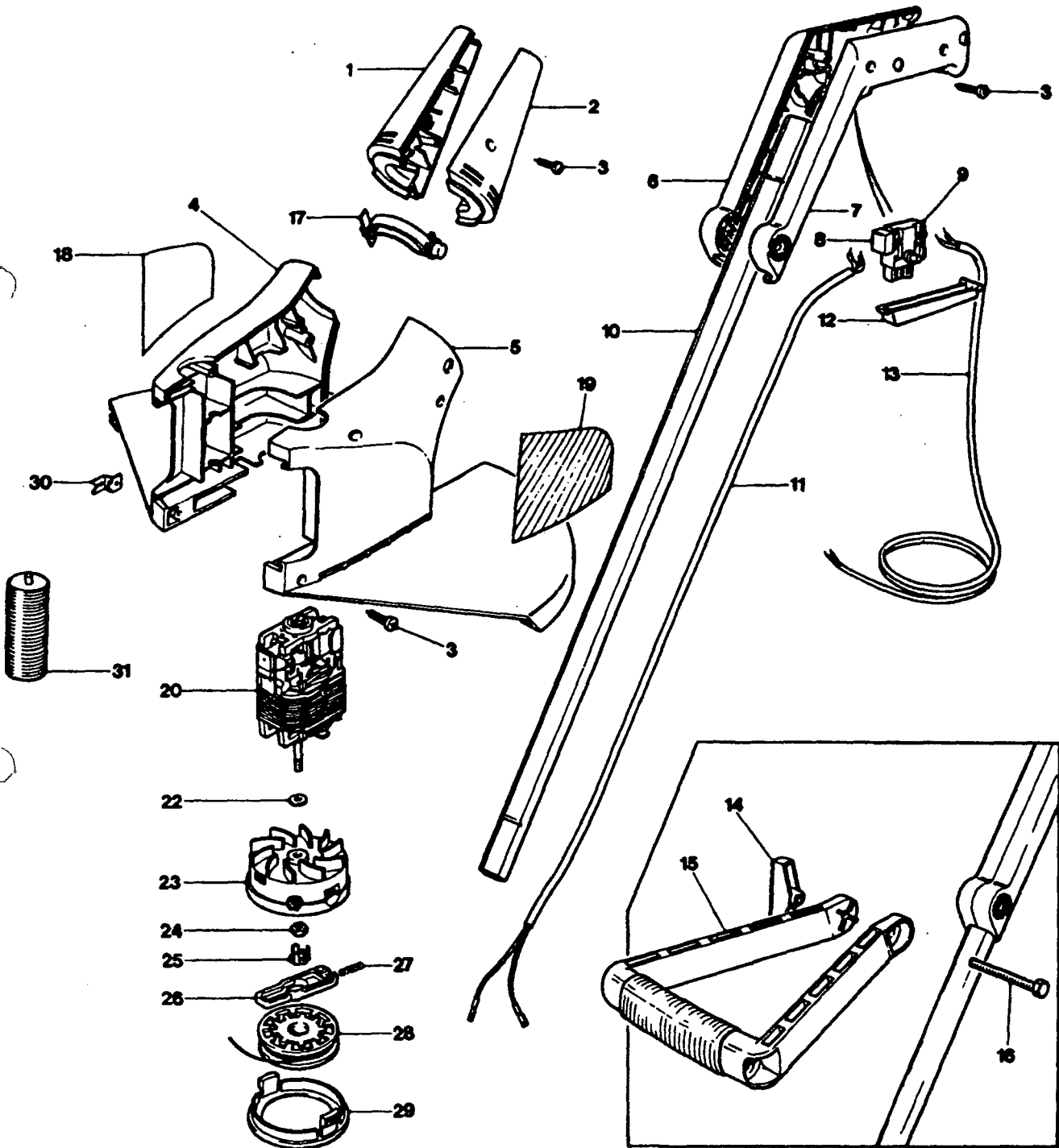

# Flymo

## Multi-trim 250-4 9648511

Key	Part No	Description	Quantity	Comments
1	5148914-00/4	Pair of swivels	1	
2	As Key 01			
3	5148552-01/0	Screw	9	
4	5148912-00/8	Pair of clamshells	1	
5	As Key 04			
6	5117224-00/5	Handle - r/h	1	
7	5117225-00/2	Handle - l/h	1	
8	5148397-01/0	Capacitor	1	
9	5137630-01/7	Switch	1	GB,EI,F,B,NL,A,E,I,D
	5136674-01/6	Switch	1	SF,N,DK,S
10	5126981-00/9	Handle tube	1	
11	5137632-01/3	Internal lead	1	
12	5137609-00/3	Switch lever	1	
13	5137738-01/8	Connecting lead	1	GB,EI
	5148282-02/2	Connecting lead	1	N,F,B,NL,A,D,DK,S,E,I
	5148282-07/1	Connecting lead	1	SF
14	5137679-00/6	Wing nut	1	
15	5117312-00/8	Assist handle	1	
16	7252384-51/1	Bolt	1	
17	5137842-00/0	Swivel lock button	1	
18	5148735-02/9	Label Multi 250 r/h	1	
19	5148735-01/1	Label Multi 250 l/h	1	
20	5126994-02/9	Motor 220/240v	1	
22	7341153-01/8	Washer	1	
	7341153-01/8	Washer	2	A,N,SF
23	5148621-01/3	Head/ferrule assy	1	
24	5148683-00/5	Nut	1	
25	5148631-00/4	Insulation cap	1	
26	5126807-00/6	Line feeder	1	
27	5148374-00/1	Spring	1	
28	5137651-01/3	Spool & line	1	
29	5126976-00/9	Spool cover	1	
30	5148353-00/5	Line cutter	1	
31	5148323-00/8	Roller	1	
36	5148253-00/7	Lock-off cover	1	
37	5126903-00/3	Splashproof ring	1	Not illustrated

A Austria;AUS Australia;B Belgium;CND Canada;CH Switzerland;D Germany;DK Denmark;E Spain;EI Eire;F France;GB Great Britain;Italy;N Norway;NL Netherlands;NZ New Zealand;O/S Overseas;P Portugal;S Sweden;SF Finland;USA America;ZA South Africa:

WHERE NO APPLICATION DETAILS ARE SHOWN,PART APPLIES TO ALL COUNTRIES

9648511-25	GB,EI	9648511-73	A	9648511-79	S
9648511-63	SF	9648511-74	DK		
9648511-71	N	9648511-77	E,I		
9648511-72	F,B,NL	9648511-78	D		